

CXPI Transceiver for Automotive

BD41001FJ-C

General Description

BD41001FJ-C can reduce EMI (Electromagnetic Emission) noise of AM frequency band in comparison with BD41000AFJ-C. BD41001FJ-C is a transceiver for the CXPI (Clock Extension Peripheral Interface) communication. Switching between Master/Slave Mode can be done using the external pin (the MS pin). Low power consumption during standby (non-communication) using Power Saving function. Arbitration function stops transmitter output upon the detection of BUS data collision. Also Fail-safe function stops transmitter output upon the detection of under voltage or temperature abnormality.

Features

- AEC-Q100 Qualified (Note 1)
- CXPI Standards Qualified
- Transmission Speed Range from 18.8 kbps to 20 kbps
- Master/Slave Switching Function
- Microcontroller Interface Corresponds to 3.3 V/5.0 V
- Built-in Terminator (30 kΩ(Typ))
- Power Saving Function
- Data Arbitration Function
- Built-in Under Voltage Lockout (UVLO) Function
- Built-in Thermal Shutdown (TSD) Function
- Low Electro Magnetic Interference (EMI)
- High Electro Magnetic Susceptibility (EMS)
- High Electro Static Discharge (ESD) Robustness

(Note 1) Grade 1

Applications

- Automotive Networks

Typical Application Circuit

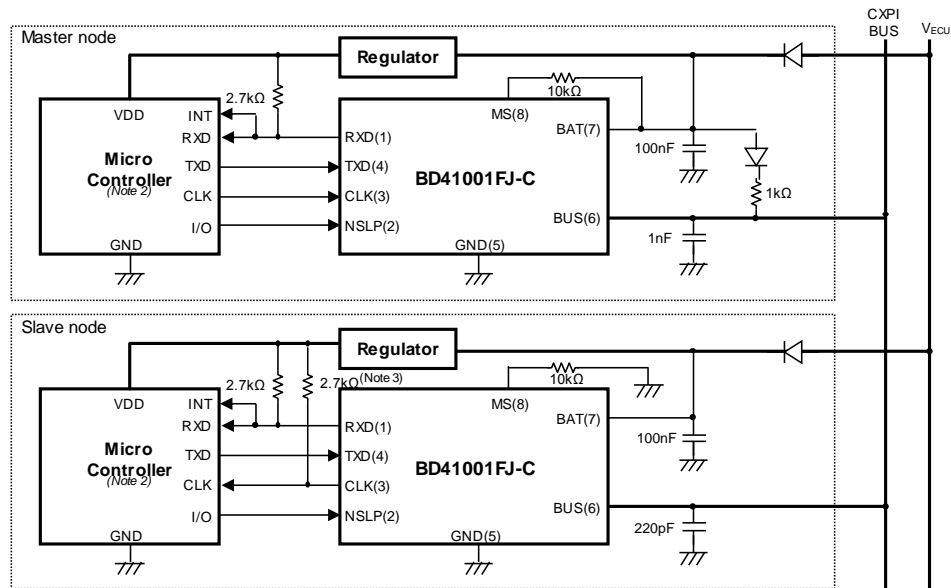

(Note 2) INT: Interrupt, RXD: UART RXD, TXD: UART TXD, CLK: Clock, I/O: General Purpose I/O

(Note 3) While using slave, it is no problem that the CLK pin is opened in the case of non-using the CLK output.

Figure 1. Typical Application Circuit

Consider the actual application design confirming the following linked document before applying this product.

- Application Note

○Product structure : Silicon monolithic integrated circuit ○This product has no designed protection against radioactive rays

Key Specifications

- Power Supply Voltage: +7 V to +18 V
- Absolute Maximum Rating of BAT: -0.3 V to +40 V
- Absolute Maximum Rating of BUS: -27 V to +40 V
- Power OFF Mode Current: 3 μA (Typ)
- Operating Temperature Range: -40 °C to +125 °C

Package

SOP-J8

W(Typ) x D(Typ) x H(Max)

4.90 mm x 6.00 mm x 1.65 mm

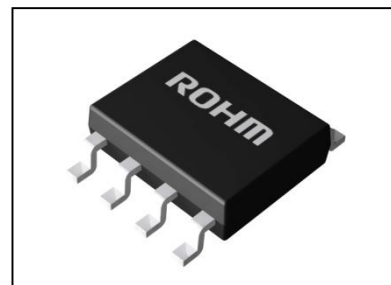

SOP-J8

Pin Configuration

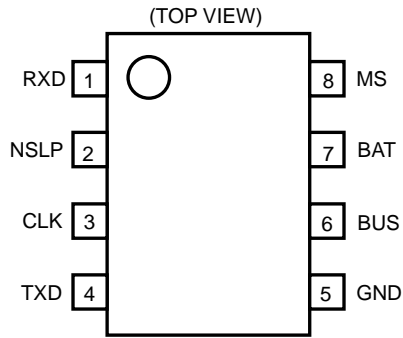

Figure 2. Pin Configuration

Pin Description

Table 1. Pin Description

Pin No.	Pin Name	Function
1	RXD	Received data output pin
2	NSLP	Power saving control input pin ("H": Change to "Codec Mode", "L": Change to "Power OFF Mode")
3	CLK	Clock signal input/output pin (Master setting: Input, Slave setting: Output)
4	TXD	Transmission data input pin
5	GND	Ground
6	BUS	CXPI BUS pin
7	BAT	Power supply pin
8	MS	Master/Slave switching pin ("H": Master, "L": Slave)

Block Diagram

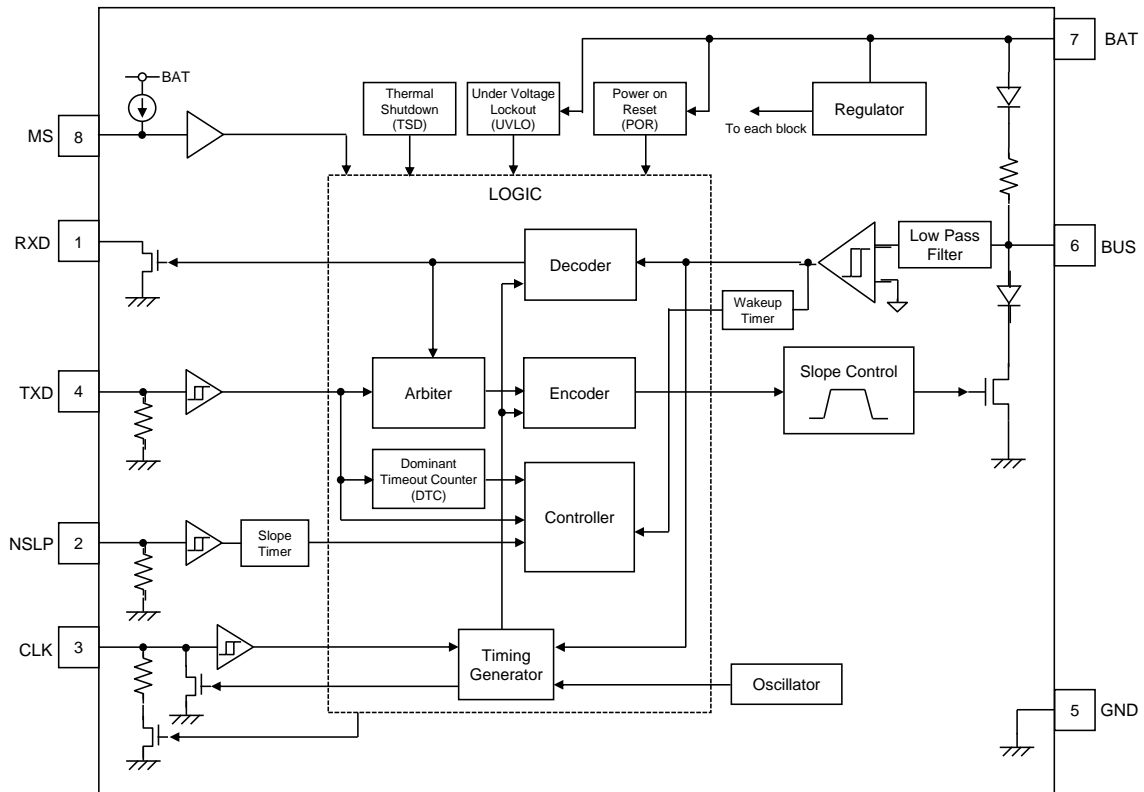
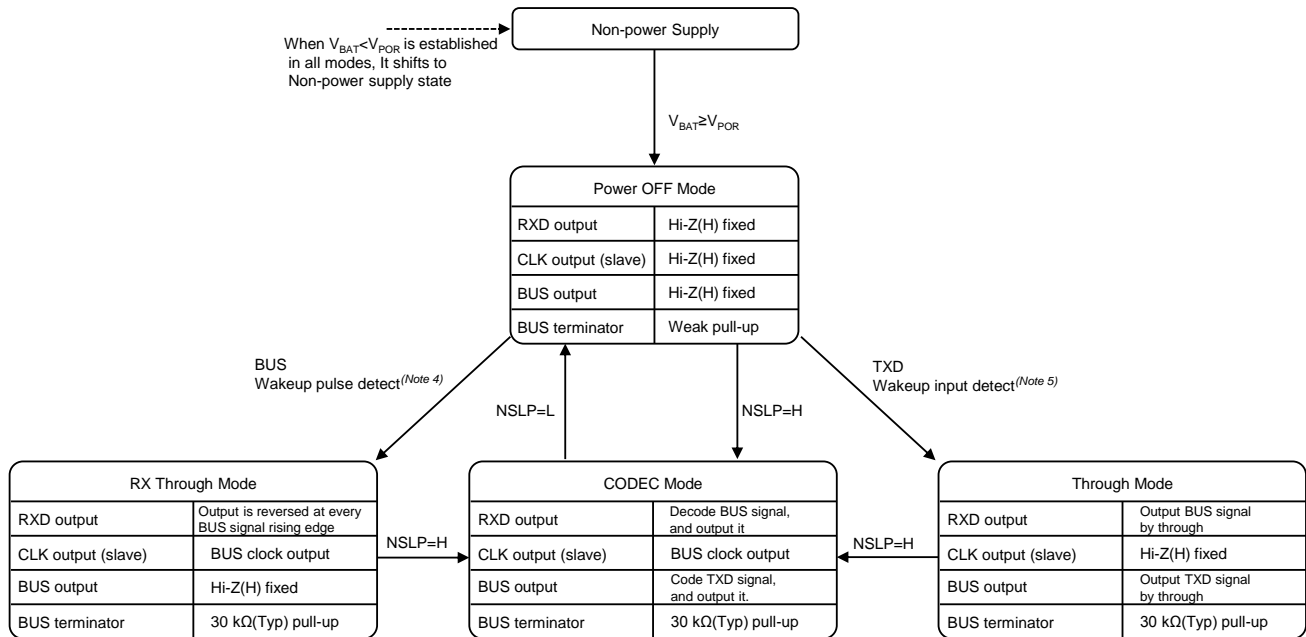

Figure 3. Block Diagram

Description of Blocks

State Transition Diagram

BD41001FJ-C has “Power OFF Mode”, “Through Mode”, “RX Through Mode” other than “CODEC Mode” for power saving control. Each mode is controlled by the NSLP, BUS, and TXD pins.



(Note 4) Refer to the Wakeup pulse detection LO time of the electrical characteristics.

(Note 5) Refer to the Wakeup input detection time (TXD) of the electrical characteristics.

Figure 4. State Transition Diagram

While using master, the CLK pin becomes input pin, and uses to input BUS clock in “CODEC Mode”.

Power OFF Mode

“Power OFF Mode” reduces power consumption by not supplying powers to any circuits other than necessary ones for “Wakeup pulse detection (the BUS pin)” and “Wakeup input detection (the TXD pin)”.

When the TXD pin is “H”, Wakeup input is detected, and then changes to “Through Mode”. If shift to “Power OFF Mode”, set the TXD pin to “L” and then set the NSLP pin to “L”.

“Through Mode” and “RX Through Mode” cannot change to “Power OFF Mode” directly. Change it via “CODEC Mode” by setting the NSLP pin to “H”.

Through Mode

“Through Mode” does not process Coding/Decoding. It only drives signals from the TXD pin to the BUS pin and from the BUS pin to the RXD pin directly.

When sending Wakeup pulse, change to “Through Mode” with the TXD pin as “H”.

RX Through Mode

“RX Through Mode” reverses the RXD pin output at each rising edge of the BUS pin.

When detecting Wakeup pulse in “Power OFF Mode”, monitor the change of the RXD pin

CODEC Mode

“CODEC Mode” is the mode of CXPI communication. NSLP should be “H” for the chip to enter “CODEC Mode”.

The RXD output changes synchronized with the falling edge of the CLK pin when in the Master setting, and with the falling edge of the BUS pin when in the Slave setting. The BUS output is delayed for $2.0 \pm 0.5 T_{bit}$ from the TXD input, and the RXD output is delayed for $1.0 \pm 0.5 T_{bit}$ from the BUS input.

For about the jitter of the clock signal supplying the CLK pin when in the Master setting, input the signal satisfies the CXPI standard ($\pm 1.0\%$) considering the jitters occurs in the BD41001FJ-C ($\pm 0.2\%$).

Description of Blocks – continued

Sequence Diagram

Show the examples of the BD41001FJ-C control sequence which corresponding to the mode management of CXPI standard, “Sleep Mode”, “Standby Mode” and “Normal Mode”.(Refer to the CXPI standard for specifications about the detail of mode management.)

1. The Sequence from “Normal Mode” to “Sleep Mode”

When changing to “Sleep Mode”, the NSLP pin should be switched from “H” to “L”, and then turn the IC to “Power OFF Mode”. The TXD pin has built-in pull-down resistor in case of a fail-safe. Fix the TXD pin to “L” before BD41001FJ-C enters “Power OFF Mode” to prevent extra currents from MCU side while “Sleep Mode”. Fix the CLK pin to “L” just like the TXD pin, because the pull-down resistor of the CLK pin is active in the case of Master setting.

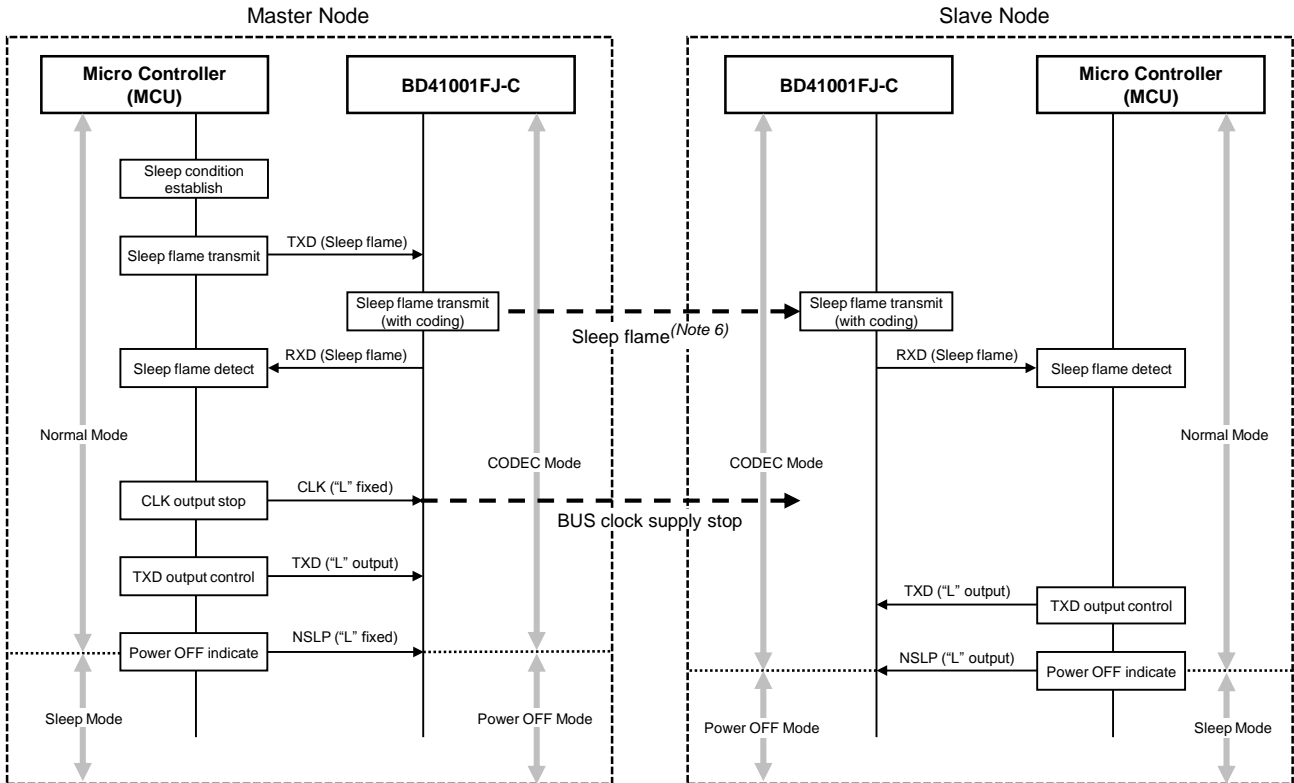

(Note 6) Refer to sleep flame shown in the JASO D015-3 standard.

Figure 5. The Sequence from “Normal Mode” to “Sleep Mode”

Master Node

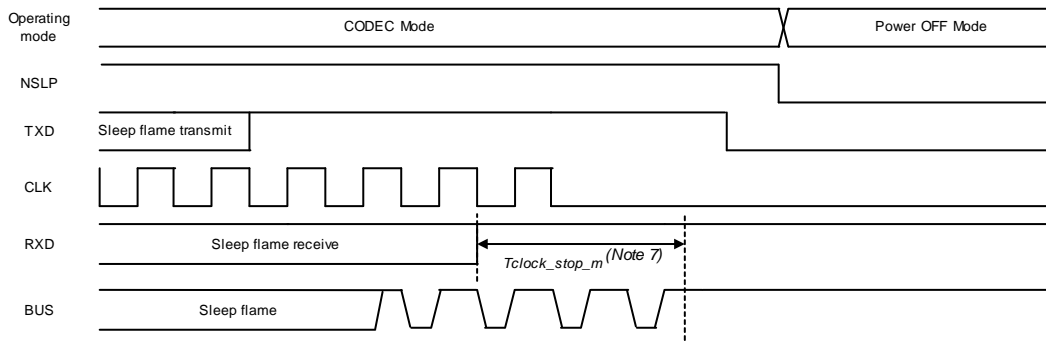

(Note 7) Refer to Tclock_stop_m shown in the JASO D015-3 standard.

Figure 6. The Timing Chart from “Normal Mode” to “Sleep Mode” (Master)

1. The Sequence from “Normal Mode” to “Sleep Mode” – continued

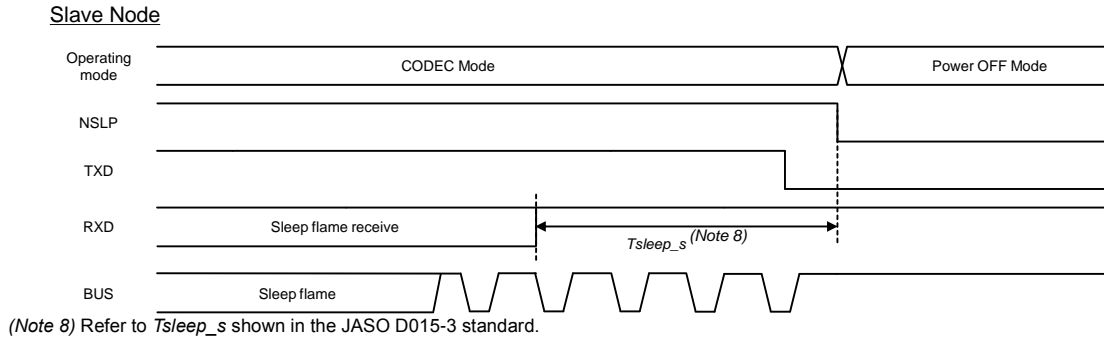

Figure 7. The Timing Chart from “Normal Mode” to “Sleep Mode” (Slave)

2. The Sequence from “Sleep Mode” to “Normal Mode” (Master Node Trigger)

To wakeup the node by an internal factor, switch the IC to “CODEC Mode” by setting the NSLP pin to “H”. The TXD pin should be “H” within 30 μ s before changing from “Power OFF Mode” to “CODEC Mode” in order to prevent abnormal the BUS output or the RXD output.

In the case of slave node, BD41001FJ-C reverses RXD output at every rising edge of the BUS signal after receiving the BUS clock. When start wakeup detecting at the RXD first falling edge, start micro controller initializing operation. To establish wakeup pulse, check if the RXD pin is “H” after initializing operation or detect RXD rising edge.

To change from “Standby Mode” to “Sleep Mode” because the slave node cannot receive the second rising pulse within the specified time, return to “Power OFF Mode” with the NSLP pin as “L” again after the change to “CODEC Mode” with the NSLP pin as “H”.

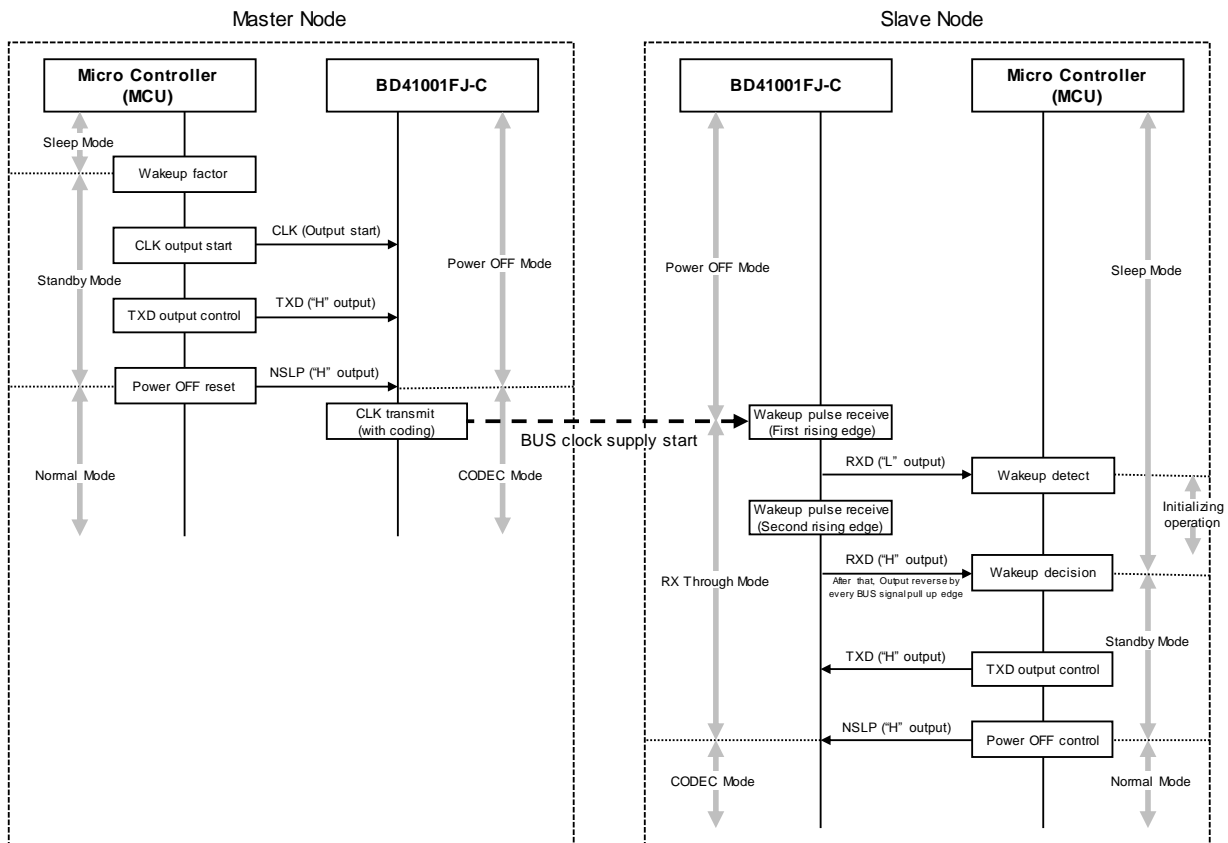

Figure 8. The Sequence from “Sleep Mode” to “Normal Mode” (Master Node Trigger)

2. The Sequence from “Sleep Mode” to “Normal Mode” (Master Node Trigger) – continued

Master Node

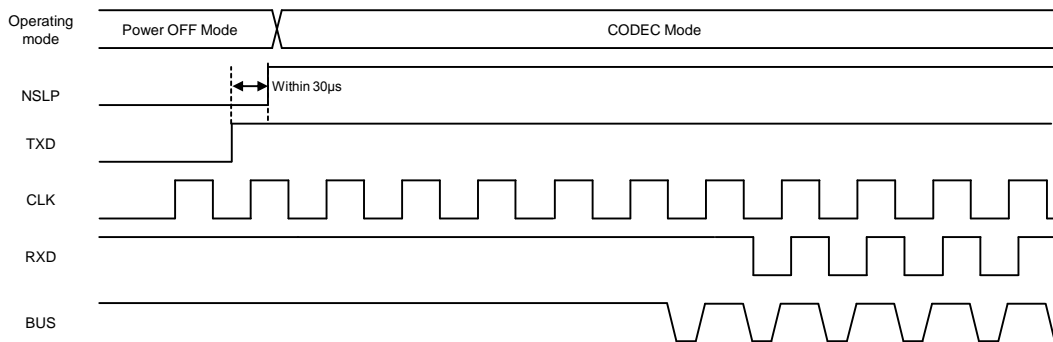

Figure 9. The Timing Chart from “Sleep Mode” to “Normal Mode” (Master Node Trigger, Master)

Slave Node

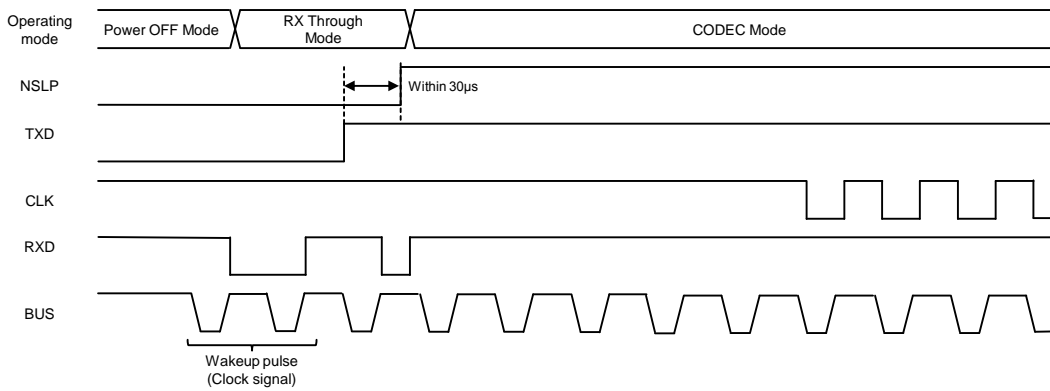

Figure 10. The Timing Chart from “Sleep Mode” to “Normal Mode” (Master Node Trigger, Slave)

Sequence Diagram – continued

3. The Sequence from “Sleep Mode” to “Normal Mode” (Slave Node Trigger)

When waking up the slave node by an internal factor, shift to “Through Mode” by setting the TXD pin to “H” and then send wakeup pulse.

After receiving the wakeup pulse in the Master Node, the RXD output reverses at every rising edge of the BUS signal. Master node should establish wakeup pulse at the RXD first falling edge.

To change from “Standby Mode” to “Sleep Mode”, in case the master node cannot receive BUS clock within the specified time, return to “Power OFF Mode” with the NSLP pin as “L” again after the change to “CODEC Mode” with the NSLP pin as “H”.

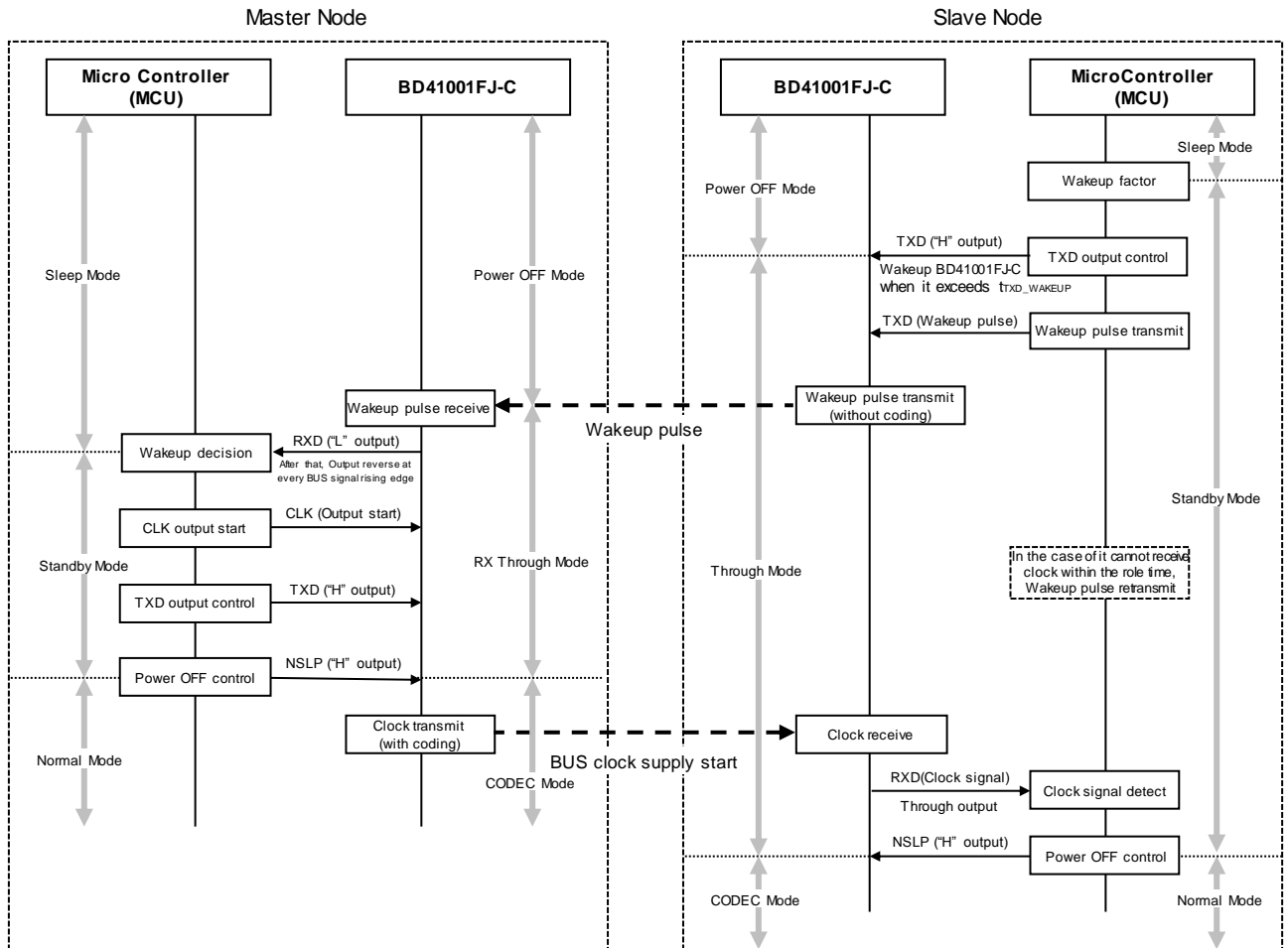
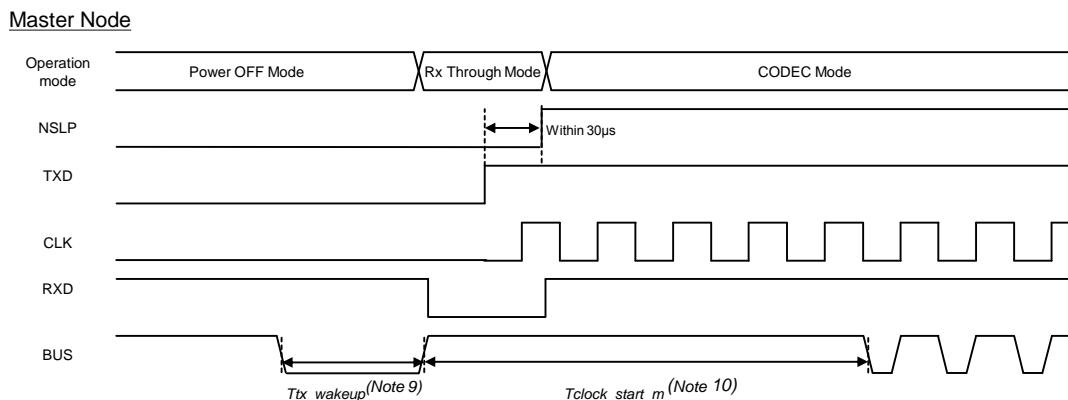

Figure 11. The Sequence from “Sleep Mode” to “Normal Mode” (Slave Node Trigger)



(Note 9) Refer to T_{x_wakeup} shown in the JASO D015-3 standard.

(Note 10) Refer to $T_{clock_start_m}$ shown in the JASO D015-3 standard.

Figure 12. The Timing Chart from “Sleep Mode” to “Normal Mode” (Slave Node Trigger, Master)

3. The Sequence from “Sleep Mode” to “Normal Mode” (Slave Node Trigger) – continued

Slave Node

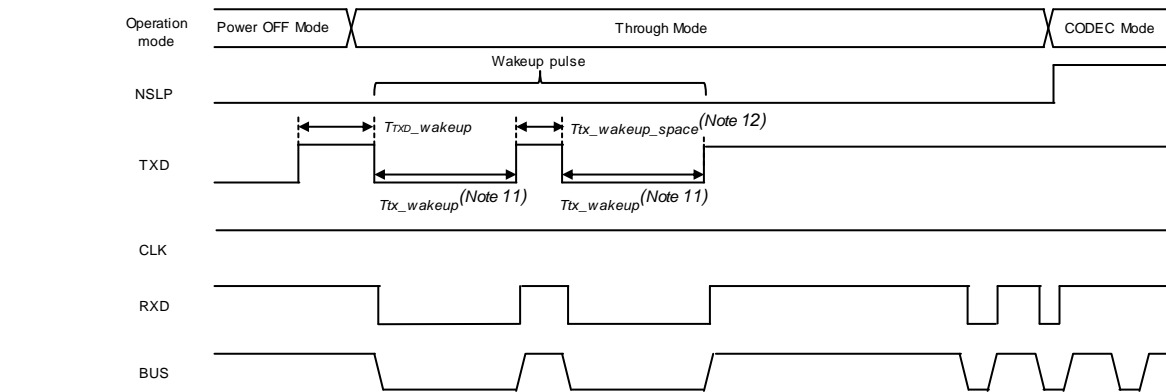

(Note 11) Refer to T_{tx_wakeup} shown in the JASO D015-3 standard.
 (Note 12) Refer to $T_{tx_wakeup_space}$ shown in the JASO D015-3 standard.

Figure 13. The Timing Chart from “Sleep Mode” to “Normal Mode” (Slave Node Trigger, Slave)

Transmission and Reception Starting Effective Time after Shift to CODEC Mode

After changing to “CODEC Mode” by setting the NSLP pin to “H”, BD41001FJ-C detect the clock period and then learn the LO width of logic value1. To secure the learning time of the LO width of logic value1, start to transmit and receive data after the time equal to 16 T_{bit} clocks at least. (After setting the NSLP pin to “H”, 6 T_{bit} (maximum) clocks are necessary to output clock signal to the BUS signal input or the CLK signal input.)

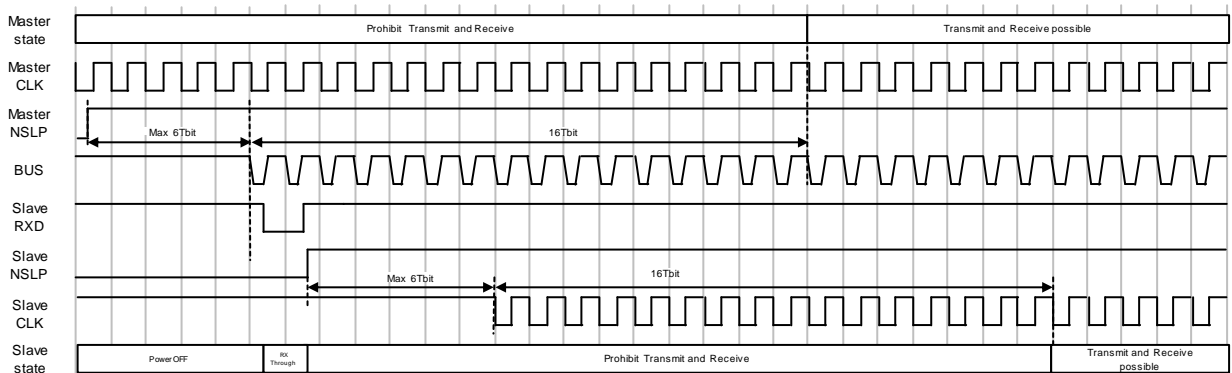

Figure 14. The Actual Time of Transmission and Reception after “CODEC Mode” Changing

Arbitration Function

To carry out collision resolution functions that defined by CXPI specification, both micro controller and BD41001FJ-C share functions. Basically, BD41001FJ-C arbitrates the bit data in the UART flame and micro controller arbitrates the byte data between the UART flames.

1. In case of collision is happened by transmitting from other node at the same time

In the case of collision (arbitration defeat) is happened by transmitting from other node at the same time, it stops the transmission of remaining UART flame data after the collision from micro controller side. It is necessary to have the interval of 1 T_{bit} or more (BUS baud rate period) to transmit again after arbitration defeat. Set the wait time in consideration of the frequency deviation of the baud rate clock in micro controller side and BUS side and the delay at UART circuit in micro controller side.

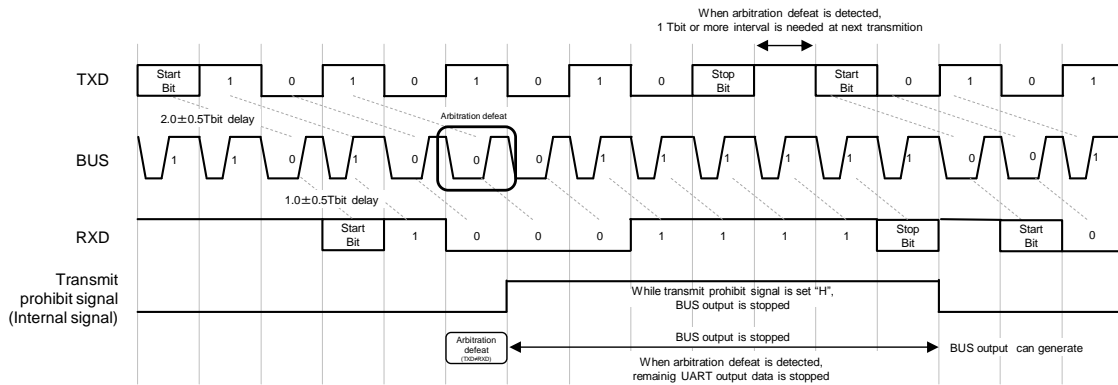

Figure 15. Arbitration Function (When the Collision is detected after Data Transmission)

2. In case of collision is detected by receiving from other node before transmission is started.

After BD41001FJ-C detects transmission of other node on BUS, BD41001FJ-C stops to transmit data for 10 T_{bit} period not to destroy other node transmission. If the TXD signal is inputted to BD41001FJ-C while stopping to transmit data, BD41001FJ-C stops to transmit data for further 10 T_{bit} period of the transmit data.

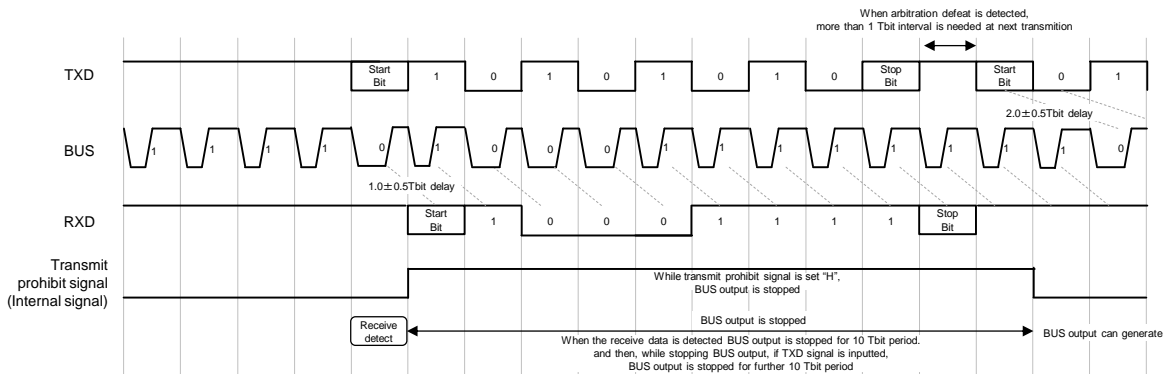

Figure 16. Arbitration Function (When receive data is detected before transmission)

Arbitration Function – continued

3. In case of arbitration function failure is happened because micro controller outputs transmission data to BD41001FJ-C at the out of range of BD41001FJ-C arbitration function.

The BUS output is delayed for 2.5 T_{bit}(Maximum) from the TXD input and the RXD output is delayed for 1.5 T_{bit}(Maximum) from BUS input. When micro controller outputs transmission data to BD41001FJ-C at the timing that shown in Figure 17, CXPI frame of other node is destroyed because BD41001FJ-C outputs PID just after receive PID.

Micro controller should stop transmission while receiving UART frame.

Figure 17 shows the example in case of 2.0 T_{bit} delay from the TXD input to the BUS output and 1.0 T_{bit} delay from the BUS input to the RXD output.

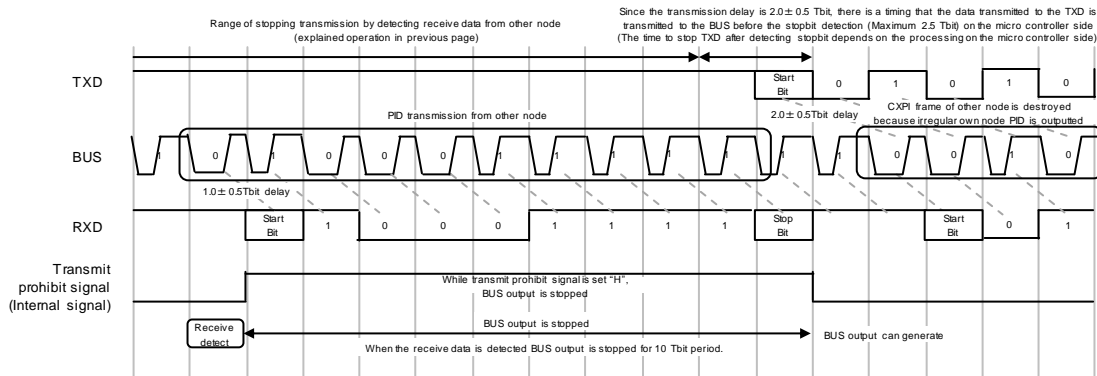

Figure 17. Arbitration Function (When micro controller detects receive data with stopbit)

In case of supporting event trigger method of CXPI standard, not to destroy CXPI frame, micro controller should detect startbit of UART receive frame before transmitting PID, and then stop transmission of PID.

Fail-safe Function

BD41001FJ-C has built in fail-safe mode such as DTC (TXD Dominant Abnormal Detection Circuit), TSD (Abnormal Thermal Detection Circuit) and UVLO/POR (Under Voltage Lockout Circuit/Power ON Reset Circuit). The operations of each abnormal situation are as follows;

Table 2. Fail-safe Functions

Fail-safe Function	State Transition	BUS Output	RXD Output	CLK Output (While using slave)
DTC abnormality	No change	CODEC Mode: Logical value1 output ^(Note 13) Through Mode: Hi-Z(H) fixed	BUS signal output	Hi-Z(H) fixed
TSD abnormality	No change	Hi-Z(H) fixed	Hi-Z(H) fixed	Hi-Z(H) fixed
UVLO abnormality	No change	Hi-Z(H) fixed	Hi-Z(H) fixed	Hi-Z(H) fixed
POR abnormality	Power OFF Mode	Hi-Z(H) fixed	Hi-Z(H) fixed	Hi-Z(H) fixed

(Note 13) In the case of TXD fixed L, Logical value0 is outputted only in first 10bit. Logical value1 is outputted before DTC abnormality is detected.

When “L” time of the TXD pin is more than t_{DTC}, DTC (Dominant Timeout Counter) detects abnormality, and then it stops output. It can return to normal status with the TXD pin as “H”

When the junction temperature exceeds T_{TSD}, TSD (Thermal Shutdown) circuit detects abnormality, and then it stops output. It can return to normal status when the temperature drops T_{TSD_HYS}.

Operations of UVLO (Under Voltage Lockout) and POR (Power ON Reset) are as follows;

When supply voltage is V_{UVLO} or less, UVLO abnormality is detected, and then the BUS, the RXD and the CLK outputs (only slave) are fixed Hi-Z(H).

When power supply When power supply is V_{UVLO} or more, transceiver restarts output. When supply voltage drops below V_{POR}, POR abnormality is detected, and then it changes to “Power OFF Mode”, and reset status.

Fail-safe Function – continued

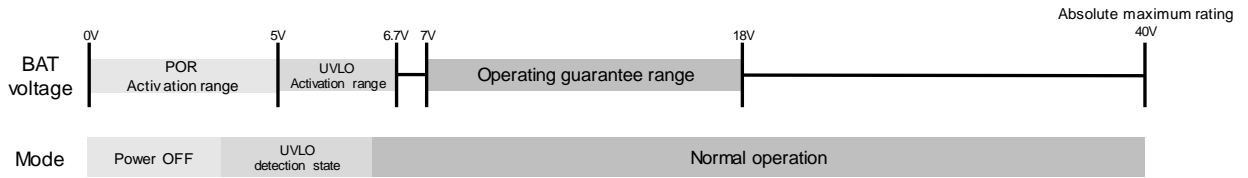

Figure 18. Internal Status and Mode by Supply Voltage

Absolute Maximum Ratings

Table 3. Absolute Maximum Ratings

Parameter	Symbol	Rating	Unit
Supply Voltage	V _{BAT}	-0.3 to +40.0	V
Input Voltage	V _{MS}	-0.3 to +40.0	V
	V _{NSLP} , V _{TXD}	-0.3 to +7.0	
Output Voltage	V _{RXD}	-0.3 to +7.0	V
Input/Output Voltage	V _{BUS}	-27.0 to +40.0	V
	V _{CLK}	-0.3 to +7.0	
Junction Max Temperature	T _{jmax}	+150	°C
Storage Temperature	T _{stg}	-55 to +150	°C
Electro Static Discharge (HBM) ^(Note 14)	V _{ESD}	4000	V

(Note 14) JEDEC qualified.

Caution 1: Operating the IC over the absolute maximum ratings may damage the IC. The damage can either be a short circuit between pins or an open circuit between pins and the internal circuitry. Therefore, it is important to consider circuit protection measures, such as adding a fuse, in case the IC is operated over the absolute maximum ratings.

Caution 2: Should by any chance the maximum junction temperature rating be exceeded the rise in temperature of the chip may result in deterioration of the properties of the chip. In case of exceeding this absolute maximum rating, design a PCB boards with thermal resistance taken into consideration by increasing board size and copper area so as not to exceed the maximum junction temperature rating.

Thermal Resistance^(Note 15)

Table 4. Thermal Resistance

Parameter	Symbol	Thermal Resistance (Typ)		Unit
		1s ^(Note 17)	2s2p ^(Note 18)	
SOP-J8				
Junction to Ambient	θ_{JA}	149.3	76.9	°C/W
Junction to Top Characterization Parameter ^(Note 16)	Ψ_{JT}	18	11	°C/W

(Note 15) Based on JEESD51-2A(Still-Air)

(Note 16) The thermal characterization parameter to report the difference between junction temperature and the temperature at the top center of the outside surface of the component package.

(Note 17) Using a PCB board based on JEESD51-3(Table 5).

(Note 18) Using a PCB board based on JEESD51-7(Table 6).

Table 5. 1 Layer Board

Layer Number of Measurement Board	Material	Board Size
Single	FR-4	114.3mm x 76.2mm x 1.57mmt
Top		
Copper Pattern	Thickness	
Footprints and Traces	70 μ m	

Table 6. 4 Layers Board

Layer Number of Measurement Board	Material	Board Size			
4 Layers	FR-4	114.3mm x 76.2mm x 1.6mmt			
Top		2 Internal Layers		Bottom	
Copper Pattern	Thickness	Copper Pattern	Thickness	Copper Pattern	Thickness
Footprints and Traces	70 μ m	74.2mm x 74.2mm	35 μ m	74.2mm x 74.2mm	70 μ m

Recommended Operating Conditions

Table 7. Recommended Operating Conditions

Parameter	Symbol	Min	Typ	Max	Unit
Supply Voltage	V_{BAT}	7.0	12.0	18.0	V
Operating Temperature	T_{opr}	-40	+25	+125	°C

Electrical Characteristics (Unless Otherwise Specified Ta=-40°C to +125°C, V_{BAT}=7V to 18V)

Table 8. Electrical Characteristics (1)

Parameter	Symbol	Min	Typ	Max	Unit	Conditions
BAT						
Supply Current 1	I _{BAT_SLP}	-	3	10	μA	After NSLP shifts from H to L
Supply Current 2	I _{BAT_NOR}	-	3	10	mA	NSLP=H, MS=H, CLK=20kHz (Duty=50%) TXD=10kHz (Duty=50%)
TXD, NLSP, CLK (When Input)						
H Level Input Voltage	V _{IHMCU_IN}	2.0	-	-	V	
L Level Input Voltage	V _{ILMCU_IN}	-	-	0.8	V	
Input H Current	I _{IHMCU_IN}	6.0	14.0	40.0	μA	Input Voltage=5V
Input L Current	I _{ILMCU_IN}	-5.0	0.0	+5.0	μA	
Wakeup Input Detection Time (TXD)	t _{TXD_WAKEUP}	30	100	150	μs	H Width
Input Clock Duty (CLK)	D _{DUTYCLK}	48	50	95	%	Duty Rule of H Width
MS						
H Level Input Voltage	V _{IHMS_IN}	V _{BAT} -1.0	-	-	V	
L Level Input Voltage	V _{ILMS_IN}	-	-	V _{BAT} -3.0	V	
Input H Current	I _{IHMS_IN}	-5.0	-	+5.0	μA	Input Voltage= V _{BAT} =18V
Input L Current	I _{ILMS_IN}	-5.0	-	+5.0	μA	In Power OFF Mode
RXD, CLK (When Output)						
Output ON Current	I _{OLMCU_OUT}	1.3	3.5	-	mA	Output Pin=0.4V
Output OFF Current	I _{OHMCU_OUT}	-5.0	0.0	+5.0	μA	Output Pin=5V
BUS (DC Characteristics)						
Recessive Output Voltage (Note 19)	V _{BUS_RES}	V _{BAT} x 0.9	-	-	V	R _L =500Ω
Dominant Output Voltage 1 (Note 19)	V _{BUS_DOM_1}	-	-	1.2	V	V _{BAT} =7V, R _L =500Ω
Dominant Output Voltage 2 (Note 19)	V _{BUS_DOM_2}	0.6	-	-	V	V _{BAT} =7V, R _L =1kΩ
Dominant Output Voltage 3 (Note 19)	V _{BUS_DOM_3}	-	-	2.0	V	V _{BAT} =18V, R _L =500Ω
Dominant Output Voltage 4 (Note 19)	V _{BUS_DOM_4}	0.8	-	-	V	V _{BAT} =18V, R _L =1kΩ
H Level Leakage Current	I _{IHBUS}	-5.0	0.0	+5.0	μA	When Recessive Output V _{BAT} =V _{BUS} =18V
Pull-up Resister	R _{BUS}	20	30	50	kΩ	V _{BAT} =12V
Short-circuit Output Current (Note 19)	I _{OCBPBUS}	40	-	200	mA	V _{BAT} =V _{BUS} =18V, R _L =0Ω
L Current at Receiver Operating	I _{OLBUS}	-1	-	-	mA	V _{BAT} =12V, V _{BUS} =0V
Input Leakage Current at Receiver Operating	I _{LBUS}	-	-	20	μA	V _{BAT} =8V, V _{BUS} =18V
Leakage Current when NO_GND	I _{LBUS_NO_GND}	-1	-	+1	mA	GND=V _{BAT} =12V, V _{BUS} =0V to 18V
Leakage Current when NO_BAT	I _{LBUS_NO_BAT}	-	-	100	μA	V _{BAT} =0V, V _{BUS} =0V to 18V
Input H Threshold Voltage	V _{IHBUS_REC}	V _{BAT} x 0.556	-	-	V	
Input L Threshold Voltage	V _{ILBUS_DOM}	-	-	V _{BAT} x 0.423	V	
Input Threshold Voltage (Typical)	V _{THCBUS}	V _{BAT} x 0.475	V _{BAT} x 0.5	V _{BAT} x 0.525	V	
Input Hysteresis Voltage	V _{HYSBUS}	-	-	V _{BAT} x 0.133	V	

(Note 19) R_L is pull-up resistor that is connected between BAT and BUS terminal outside.

Electrical Characteristics – continued

Table 9. Electrical Characteristics (2)

Parameter	Symbol	Min	Typ	Max	Unit	Conditions
BUS (AC Characteristics)						
LO Level Time 1 of Logical Value "1" (Note 20)	$t_{TX_1_LO_REC}$	-	-	$0.39T_{bit} + 0.6\tau$	-	$t_{H_REC}=70\%$
LO Level Time 2 of Logical Value "1"	$t_{TX_1_LO_DOM}$	0.11	-	-	T_{bit}	$t_{H_DOM}=30\%$
HI Detection Time of Receiving	$t_{TX_0_HI}$	0.06	-	-	T_{bit}	$t_{H_REC}=55.6\%$
Difference of LO Level Time between Logical Value "1" and Logical Value "0"	t_{TX_DIF}	0.06	-	-	T_{bit}	$t_{TX_DIF} = t_{TX_0_LO} - t_{TX_1_LO}$
Delay Time from the LO Level Detection to Logical Value "0" Output	$t_{TX_0_PD}$	-	-	0.11	T_{bit}	$t_{H_DOM}=30\%$
LO Time 1 of Logical Value "0"	$t_{TX_0_LO_REC}$	$t_{TX_1_LO_REC} + 0.06$	-	-	T_{bit}	$t_{H_REC}=70\%$
LO Time 2 of Logical Value "0"	$t_{TX_0_LO_DOM}$	$t_{TX_1_LO_DOM} + 0.06$	-	-	T_{bit}	$t_{H_DOM}=30\%$
BUS Pull-down Time	$t_{TX_1_DOM_M}$	-	-	0.16	T_{bit}	$t_{H_DOM}=30\%$
Recessive Voltage of Logical Value "0"	V_{REC_0}	93	-	-	%	Ratio for the Recessive Voltage (V_{REC_1}) when logical value is 1
Wakeup Pulse Detection LO Time for Master Setting	$t_{RX_WAKEUP_MASTER}$	30	100	150	μs	$t_{H_DOM}=42.3\%$
Wakeup Pulse Detection LO Time for Slave Setting	$t_{RX_WAKEUP_SLAVE}$	0.5	3	5	μs	$t_{H_DOM}=42.3\%$
TSD						
TSD Detection Temperature (Note 21)	T_{TSD}	150	-	200	$^{\circ}C$	
TSD Hysteresis Temperature (Note 21)	T_{TSD_HYS}	-	14	-	$^{\circ}C$	
UVLO						
UVLO Detection Voltage	V_{UVLO}	5.0	-	6.7	V	
POR						
POR Detection Voltage	V_{POR}	-	-	5.0	V	
DTC						
Dominant Time-out Time	t_{DTC}	9	13	22	ms	

(Note 20) τ is a fixed number when BUS ($1\mu s \leq \tau \leq 5\mu s$)

(Note 21) It is a design guarantee parameter, and is not production tested.

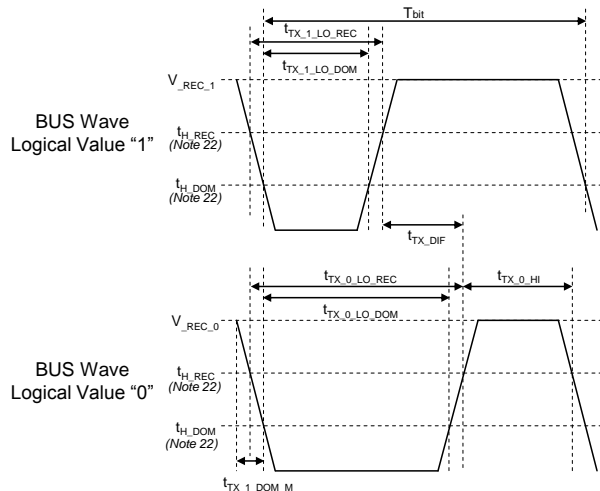

(Note 22) These parameters are shown as the ratio of V_{BAT} .

Figure 19. BUS Waves of Logical Value 1, 0

Application Example

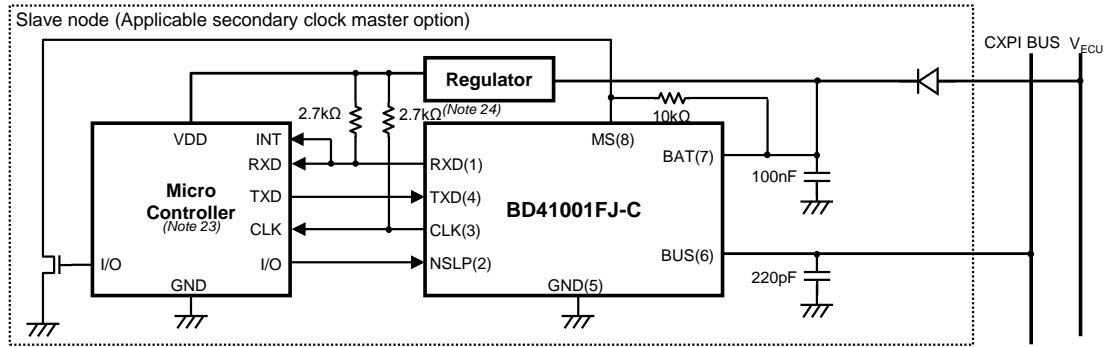

(Note 23) INT: Interrupt, RXD: UART RXD, TXD: UART TXD, CLK: Clock, I/O: General Purpose I/O
 (Note 24) While using slave, it is no problem that the CLK pin is opened in the case of non-using the CLK output.
 Figure 20. Application Example of Secondary Clock Master Option

I/O Equivalence Circuits

Type	Equivalence Circuit	Type	Equivalence Circuit
A	<p>Output pin: RXD</p>	B	<p>Input pin: NSLP, TXD</p>
C	<p>Input/output pin: CLK</p>	D	<p>CXPI BUS Input/output pin: BUS</p>
E	<p>Input pin: MS</p>		

Operational Notes

1. Reverse Connection of Power Supply

Connecting the power supply in reverse polarity can damage the IC. Take precautions against reverse polarity when connecting the power supply, such as mounting an external diode between the power supply and the IC's power supply pins.

2. Power Supply Lines

Design the PCB layout pattern to provide low impedance supply lines. Furthermore, connect a capacitor to ground at all power supply pins. Consider the effect of temperature and aging on the capacitance value when using electrolytic capacitors.

3. Ground Voltage

Ensure that no pins are at a voltage below that of the ground pin at any time, even during transient condition.

4. Ground Wiring Pattern

When using both small-signal and large-current ground traces, the two ground traces should be routed separately but connected to a single ground at the reference point of the application board to avoid fluctuations in the small-signal ground caused by large currents. Also ensure that the ground traces of external components do not cause variations on the ground voltage. The ground lines must be as short and thick as possible to reduce line impedance.

5. Recommended Operating Conditions

The function and operation of the IC are guaranteed within the range specified by the recommended operating conditions. The characteristic values are guaranteed only under the conditions of each item specified by the electrical characteristics.

6. Inrush Current

When power is first supplied to the IC, it is possible that the internal logic may be unstable and inrush current may flow instantaneously due to the internal powering sequence and delays, especially if the IC has more than one power supply. Therefore, give special consideration to power coupling capacitance, power wiring, width of ground wiring, and routing of connections.

7. Operation Under Strong Electromagnetic Field

Operating the IC in the presence of a strong electromagnetic field may cause the IC to malfunction.

8. Testing on Application Boards

When testing the IC on an application board, connecting a capacitor directly to a low-impedance output pin may subject the IC to stress. Always discharge capacitors completely after each process or step. The IC's power supply should always be turned off completely before connecting or removing it from the test setup during the inspection process. To prevent damage from static discharge, ground the IC during assembly and use similar precautions during transport and storage.

9. Inter-pin Short and Mounting Errors

Ensure that the direction and position are correct when mounting the IC on the PCB. Incorrect mounting may result in damaging the IC. Avoid nearby pins being shorted to each other especially to ground, power supply and output pin. Inter-pin shorts could be due to many reasons such as metal particles, water droplets (in very humid environment) and unintentional solder bridge deposited in between pins during assembly to name a few.

10. Unused Input Pins

Input pins of an IC are often connected to the gate of a MOS transistor. The gate has extremely high impedance and extremely low capacitance. If left unconnected, the electric field from the outside can easily charge it. The small charge acquired in this way is enough to produce a significant effect on the conduction through the transistor and cause unexpected operation of the IC. So unless otherwise specified, unused input pins should be connected to the power supply or ground line.

Operational Notes – continued

11. Regarding the Input Pin of the IC

This monolithic IC contains P+ isolation and P substrate layers between adjacent elements in order to keep them isolated. P-N junctions are formed at the intersection of the P layers with the N layers of other elements, creating a parasitic diode or transistor. For example (refer to figure below):

When $GND > Pin A$ and $GND > Pin B$, the P-N junction operates as a parasitic diode.

When $GND > Pin B$, the P-N junction operates as a parasitic transistor.

Parasitic diodes inevitably occur in the structure of the IC. The operation of parasitic diodes can result in mutual interference among circuits, operational faults, or physical damage. Therefore, conditions that cause these diodes to operate, such as applying a voltage lower than the GND voltage to an input pin (and thus to the P substrate) should be avoided.

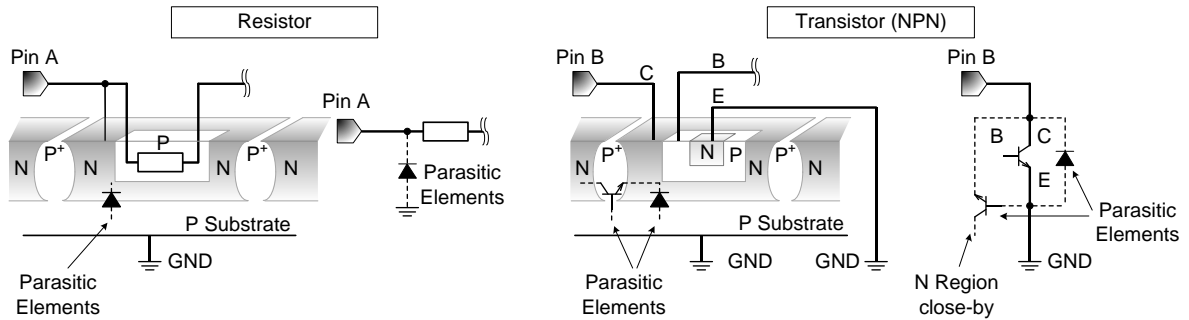

Figure 21. Example of Monolithic IC Structure

12. Ceramic Capacitor

When using a ceramic capacitor, determine a capacitance value considering the change of capacitance with temperature and the decrease in nominal capacitance due to DC bias and others.

13. Area of Safe Operation (ASO)

Operate the IC such that the output voltage, output current, and the maximum junction temperature rating are all within the Area of Safe Operation (ASO).

14. Thermal Shutdown Circuit (TSD)

This IC has a built-in thermal shutdown circuit that prevents heat damage to the IC. Normal operation should always be within the IC's maximum junction temperature rating. If however the rating is exceeded for a continued period, the junction temperature (T_j) will rise which will activate the TSD circuit that will turn OFF power output pins. When the T_j falls below the TSD threshold, the circuits are automatically restored to normal operation.

Note that the TSD circuit operates in a situation that exceeds the absolute maximum ratings and therefore, under no circumstances, should the TSD circuit be used in a set design or for any purpose other than protecting the IC from heat damage.

Ordering Information

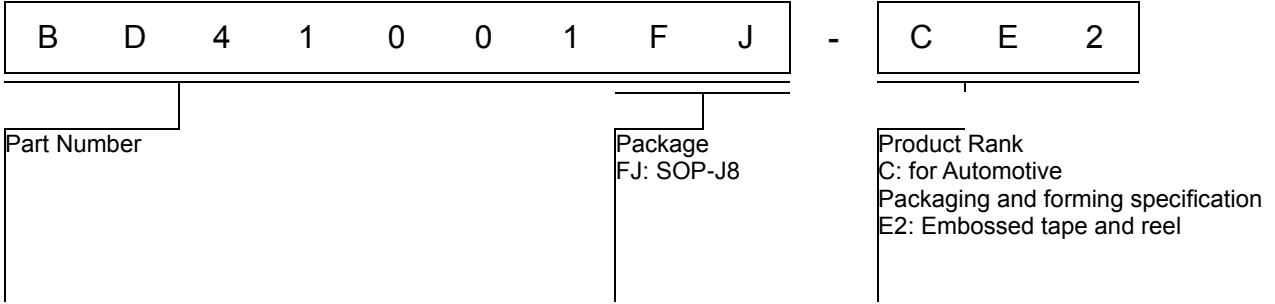

Marking Diagram

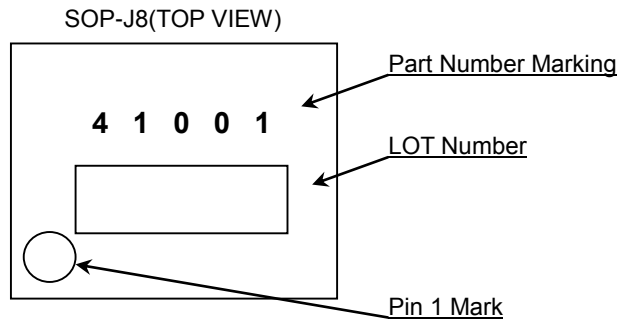

Physical Dimension and Packing Information

Package Name	SOP-J8
--------------	--------

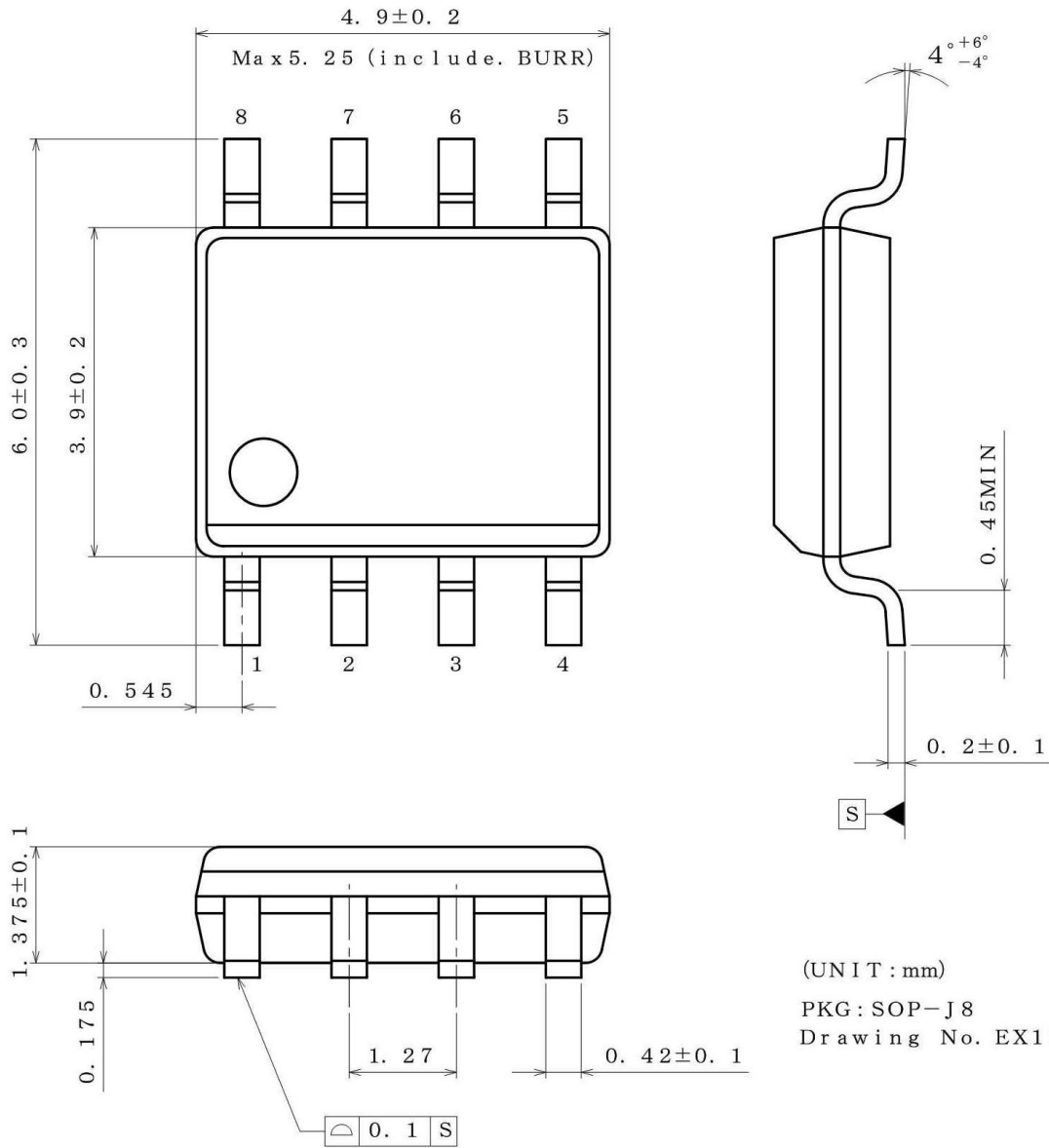

(UNIT : mm)
 PKG : SOP-J8
 Drawing No. EX111-5002

<Tape and Reel information>

Tape	Embossed carrier tape
Quantity	2500pcs
Direction of feed	E2 (The direction is the 1pin of product is at the upper left when you hold reel on the left hand and you pull out the tape on the right hand)

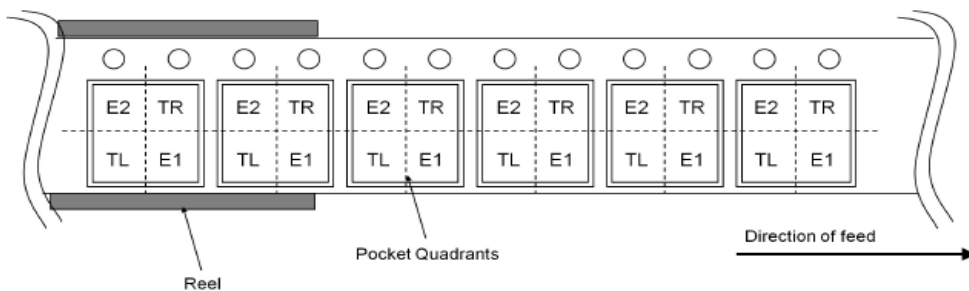

Revision History

Date	Revision	Changes
16.Mar.2018	001	New Release
26.Mar.2019	002	P1 Added the ApplicationNote information P9 1. In case of collision is happened by transmitting from other node at the same time Added a caution about the time to validate the transmit after an arbitration defeat occurred.

Notice

Precaution on using ROHM Products

1. If you intend to use our Products in devices requiring extremely high reliability (such as medical equipment ^(Note 1), aircraft/spacecraft, nuclear power controllers, etc.) and whose malfunction or failure may cause loss of human life, bodily injury or serious damage to property ("Specific Applications"), please consult with the ROHM sales representative in advance. Unless otherwise agreed in writing by ROHM in advance, ROHM shall not be in any way responsible or liable for any damages, expenses or losses incurred by you or third parties arising from the use of any ROHM's Products for Specific Applications.

(Note1) Medical Equipment Classification of the Specific Applications

JAPAN	USA	EU	CHINA
CLASS III	CLASS III	CLASS II b	CLASS III
CLASS IV		CLASS III	

2. ROHM designs and manufactures its Products subject to strict quality control system. However, semiconductor products can fail or malfunction at a certain rate. Please be sure to implement, at your own responsibilities, adequate safety measures including but not limited to fail-safe design against the physical injury, damage to any property, which a failure or malfunction of our Products may cause. The following are examples of safety measures:
 - [a] Installation of protection circuits or other protective devices to improve system safety
 - [b] Installation of redundant circuits to reduce the impact of single or multiple circuit failure
3. Our Products are not designed under any special or extraordinary environments or conditions, as exemplified below. Accordingly, ROHM shall not be in any way responsible or liable for any damages, expenses or losses arising from the use of any ROHM's Products under any special or extraordinary environments or conditions. If you intend to use our Products under any special or extraordinary environments or conditions (as exemplified below), your independent verification and confirmation of product performance, reliability, etc. prior to use, must be necessary:
 - [a] Use of our Products in any types of liquid, including water, oils, chemicals, and organic solvents
 - [b] Use of our Products outdoors or in places where the Products are exposed to direct sunlight or dust
 - [c] Use of our Products in places where the Products are exposed to sea wind or corrosive gases, including Cl₂, H₂S, NH₃, SO₂, and NO₂
 - [d] Use of our Products in places where the Products are exposed to static electricity or electromagnetic waves
 - [e] Use of our Products in proximity to heat-producing components, plastic cords, or other flammable items
 - [f] Sealing or coating our Products with resin or other coating materials
 - [g] Use of our Products without cleaning residue of flux (Exclude cases where no-clean type fluxes is used. However, recommend sufficiently about the residue.); or Washing our Products by using water or water-soluble cleaning agents for cleaning residue after soldering
 - [h] Use of the Products in places subject to dew condensation
4. The Products are not subject to radiation-proof design.
5. Please verify and confirm characteristics of the final or mounted products in using the Products.
6. In particular, if a transient load (a large amount of load applied in a short period of time, such as pulse, is applied, confirmation of performance characteristics after on-board mounting is strongly recommended. Avoid applying power exceeding normal rated power; exceeding the power rating under steady-state loading condition may negatively affect product performance and reliability.
7. De-rate Power Dissipation depending on ambient temperature. When used in sealed area, confirm that it is the use in the range that does not exceed the maximum junction temperature.
8. Confirm that operation temperature is within the specified range described in the product specification.
9. ROHM shall not be in any way responsible or liable for failure induced under deviant condition from what is defined in this document.

Precaution for Mounting / Circuit board design

1. When a highly active halogenous (chlorine, bromine, etc.) flux is used, the residue of flux may negatively affect product performance and reliability.
2. In principle, the reflow soldering method must be used on a surface-mount products, the flow soldering method must be used on a through hole mount products. If the flow soldering method is preferred on a surface-mount products, please consult with the ROHM representative in advance.

For details, please refer to ROHM Mounting specification

Precautions Regarding Application Examples and External Circuits

1. If change is made to the constant of an external circuit, please allow a sufficient margin considering variations of the characteristics of the Products and external components, including transient characteristics, as well as static characteristics.
2. You agree that application notes, reference designs, and associated data and information contained in this document are presented only as guidance for Products use. Therefore, in case you use such information, you are solely responsible for it and you must exercise your own independent verification and judgment in the use of such information contained in this document. ROHM shall not be in any way responsible or liable for any damages, expenses or losses incurred by you or third parties arising from the use of such information.

Precaution for Electrostatic

This Product is electrostatic sensitive product, which may be damaged due to electrostatic discharge. Please take proper caution in your manufacturing process and storage so that voltage exceeding the Products maximum rating will not be applied to Products. Please take special care under dry condition (e.g. Grounding of human body / equipment / solder iron, isolation from charged objects, setting of Ionizer, friction prevention and temperature / humidity control).

Precaution for Storage / Transportation

1. Product performance and soldered connections may deteriorate if the Products are stored in the places where:
 - [a] the Products are exposed to sea winds or corrosive gases, including Cl₂, H₂S, NH₃, SO₂, and NO₂
 - [b] the temperature or humidity exceeds those recommended by ROHM
 - [c] the Products are exposed to direct sunshine or condensation
 - [d] the Products are exposed to high Electrostatic
2. Even under ROHM recommended storage condition, solderability of products out of recommended storage time period may be degraded. It is strongly recommended to confirm solderability before using Products of which storage time is exceeding the recommended storage time period.
3. Store / transport cartons in the correct direction, which is indicated on a carton with a symbol. Otherwise bent leads may occur due to excessive stress applied when dropping of a carton.
4. Use Products within the specified time after opening a humidity barrier bag. Baking is required before using Products of which storage time is exceeding the recommended storage time period.

Precaution for Product Label

A two-dimensional barcode printed on ROHM Products label is for ROHM's internal use only.

Precaution for Disposition

When disposing Products please dispose them properly using an authorized industry waste company.

Precaution for Foreign Exchange and Foreign Trade act

Since concerned goods might be fallen under listed items of export control prescribed by Foreign exchange and Foreign trade act, please consult with ROHM in case of export.

Precaution Regarding Intellectual Property Rights

1. All information and data including but not limited to application example contained in this document is for reference only. ROHM does not warrant that foregoing information or data will not infringe any intellectual property rights or any other rights of any third party regarding such information or data.
2. ROHM shall not have any obligations where the claims, actions or demands arising from the combination of the Products with other articles such as components, circuits, systems or external equipment (including software).
3. No license, expressly or implied, is granted hereby under any intellectual property rights or other rights of ROHM or any third parties with respect to the Products or the information contained in this document. Provided, however, that ROHM will not assert its intellectual property rights or other rights against you or your customers to the extent necessary to manufacture or sell products containing the Products, subject to the terms and conditions herein.

Other Precaution

1. This document may not be reprinted or reproduced, in whole or in part, without prior written consent of ROHM.
2. The Products may not be disassembled, converted, modified, reproduced or otherwise changed without prior written consent of ROHM.
3. In no event shall you use in any way whatsoever the Products and the related technical information contained in the Products or this document for any military purposes, including but not limited to, the development of mass-destruction weapons.
4. The proper names of companies or products described in this document are trademarks or registered trademarks of ROHM, its affiliated companies or third parties.

General Precaution

1. Before you use our Products, you are requested to carefully read this document and fully understand its contents. ROHM shall not be in any way responsible or liable for failure, malfunction or accident arising from the use of any ROHM's Products against warning, caution or note contained in this document.
2. All information contained in this document is current as of the issuing date and subject to change without any prior notice. Before purchasing or using ROHM's Products, please confirm the latest information with a ROHM sales representative.
3. The information contained in this document is provided on an "as is" basis and ROHM does not warrant that all information contained in this document is accurate and/or error-free. ROHM shall not be in any way responsible or liable for any damages, expenses or losses incurred by you or third parties resulting from inaccuracy or errors of or concerning such information.