

19 V - 90 W adapter with PFC for laptop computers using the L6563H and L6699

Introduction

This application note describes the performance of a 90 W, wide-range mains, power-factor corrected, AC-DC adapter demonstration board. Its electrical specifications are tailored to a typical hi-end portable computer power adapter.

The architecture is based on a two-stage approach; a front-end PFC pre-regulator based on the L6563H TM PFC controller and a downstream LLC resonant half bridge converter using the new L6699 resonant controller. Thanks to the chipset used, the main features of this design are very high efficiency, compliant with ENERGY STAR[®] eligibility criteria (EPA rev. 2.0 EPS) and very good efficiency also at light load, and compliance to the new ErP Lot 6 Tier2 requirements. No load input power consumption is very low too, well within the international regulation limits.

The controller of the LLC stage is the L6699, integrating innovative functions such as self-adjusting adaptive deadtime, anti-capacitive mode protection and proprietary “safe-start” procedure preventing hard switching at startup.

Figure 1. EVL6699-90WADP: 90 W adapter demonstration board

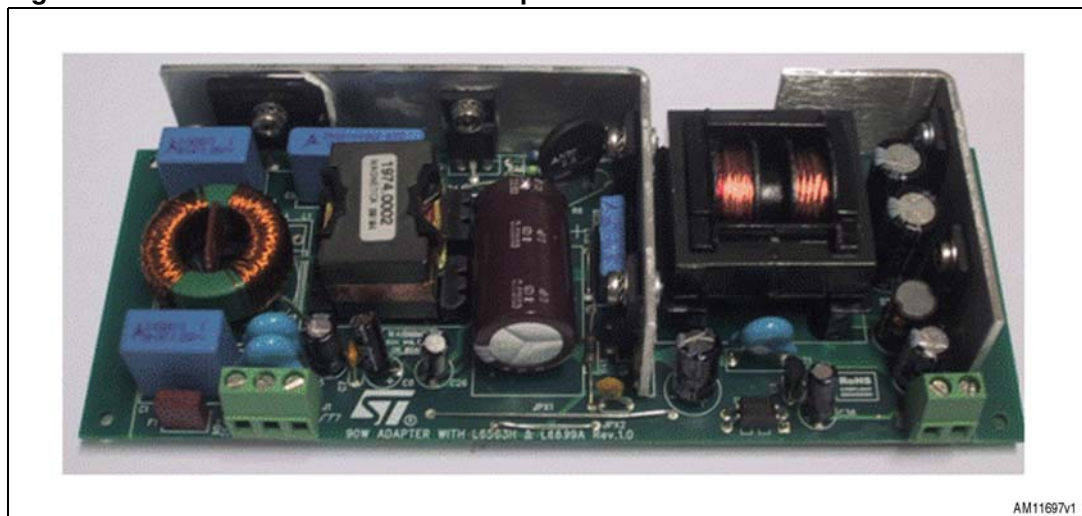

Contents

1	Main characteristics and circuit description	6
1.1	Startup sequence	6
1.2	Brownout protection	6
1.3	Fast voltage feed-forward	7
1.4	Resonant power stage	7
1.5	Output voltage feedback loop	8
1.6	L6699 overload and short-circuit protection	8
1.7	Overvoltage and open loop protection	9
1.8	Light load operation	9
2	Efficiency measurements	12
2.1	Light load operation efficiency	13
3	Harmonic content measurement	15
4	Functional check	17
4.1	Burst mode operation	19
4.2	Startup	20
4.3	Overcurrent and short-circuit protection	21
4.4	Anti-capacitive mode protection	23
5	Thermal map	25
6	Conducted emission pre-compliance test	27
7	Bill of material	29
8	PFC coil specifications	35
8.1	General description and characteristics	35
8.2	Electrical characteristics	35
8.3	Electrical diagram and winding characteristics	35
8.4	Mechanical aspect and pin numbering	36

9	Transformer specifications	37
9.1	General description and characteristics	37
9.2	Electrical characteristics	37
9.3	Electrical diagram and winding characteristics	37
9.4	Mechanical aspect and pin numbering	38
10	Revision history	39

List of tables

Table 1.	Overall efficiency	12
Table 2.	Light load efficiency	13
Table 3.	Thermal map reference points	25
Table 4.	Bill of material	29
Table 5.	PFC coil winding data	35
Table 6.	Transformer winding data	38
Table 7.	Document revision history	39

List of figures

Figure 1.	EVL6699-90WADP: 90 W adapter demonstration board	1
Figure 2.	Electrical diagram	11
Figure 3.	Efficiency vs. output power diagram	12
Figure 4.	Light load efficiency diagram	14
Figure 5.	Compliance to EN61000-3-2 at 230 Vac - 50 Hz, full load	15
Figure 6.	Compliance to JEITA-MITI at 100 Vac - 60 Hz, full load.	15
Figure 7.	Mains voltage and current waveforms at 230 V - 50 Hz - full load	16
Figure 8.	Mains voltage and current waveforms at 100 V - 60 Hz - full load	16
Figure 9.	Resonant stage waveforms at 115 V - 60 Hz - full load	17
Figure 10.	Rectifier waveforms at 115 V - 50 Hz - full load	17
Figure 11.	HB transition at full load - rising edge	18
Figure 12.	HB transition at full load - falling edge	18
Figure 13.	HB transition at 0.25 A - rising edge	18
Figure 14.	HB transition at 0.25 A - falling edge	18
Figure 15.	L6699 pin signals-1	19
Figure 16.	L6699 pin signals-2	19
Figure 17.	Pout = 250 mW operation	20
Figure 18.	Pout = 250 mW operation - detail	20
Figure 19.	Startup at 90 Vac - full load	20
Figure 20.	Startup at 265 Vac - no load	20
Figure 21.	Startup at full load	21
Figure 22.	Startup at full load - detail	21
Figure 23.	Short-circuit at full load	22
Figure 24.	Short-circuit at full load - detail	22
Figure 25.	Short-circuit - hiccup mode	23
Figure 26.	Thermal map at 115 Vac - 60 Hz - full load	25
Figure 27.	Thermal map at 230 Vac - 50 Hz - full load	25
Figure 28.	CE peak measurement at 115 Vac and full load	27
Figure 29.	CE average measurement at 230 Vac and full load	28
Figure 30.	PFC coil electrical diagram	35
Figure 31.	PFC coil mechanical aspect	36
Figure 32.	Transformer electrical diagram	37
Figure 33.	Transformer overall drawing	38

1 Main characteristics and circuit description

The main features of the SMPS are listed here below:

- Universal input mains range: from 90 to 264 Vac - frequency from 45 to 65 Hz
- Output voltage: 19 V at 4.75 A continuous operation
- Mains harmonics: meets EN61000-3-2 Class-D and JEITA-MITI Class-D
- No load mains consumption: according to ENERGY STAR 2.0 for external power supplies
- Average efficiency: according to ENERGY STAR 2.0 for external power supplies
- Light load efficiency: according to ErP Lot 6 Tier2 requirements
- EMI: within EN55022-Class-B limits
- Safety: meets EN60950
- Dimensions: 65 x 151 mm, 25 mm components maximum height
- PCB: double side, 70 μ m, FR-4, mixed PTH/SMT.

The circuit is made up of two stages: a front-end PFC using the L6563H and an LLC resonant converter featuring the L6699.

The PFC stage works as pre-regulator and powers the resonant stage with a constant voltage of 400 V. The downstream converter operates only if the PFC is working and regulating its output voltage. In this way, the resonant stage can be optimized for a narrow input voltage range improving the efficiency of the primary side power components.

1.1 Startup sequence

As previously indicated, the PFC acts as master and the resonant stage can operate only if the PFC output is delivering its rated output voltage. Therefore the circuit is designed so that at startup the PFC starts first, the downstream converter then turns on by means of the LINE pin (#7). At the beginning, the L6563H is supplied by the integrated high-voltage startup circuit; once the PFC starts switching, a charging pump connected to the PFC inductor supplies both PFC and resonant controllers. Once both stages are working, the controllers are supplied also by the auxiliary winding of the resonant transformer, assuring correct supply voltage even during standby operation.

After reaching the turn-on threshold on the VCC pin the L6563H integrated HV startup circuit is turned off and it is therefore not dissipative during normal operation, significantly contributing to the reduction of input power consumption once the power supply operates at light load, and meeting the standby worldwide efficiency standards that are currently required.

1.2 Brownout protection

Brownout protection prevents the circuit from working with abnormal mains levels. It is easily achieved using the pin RUN (#12) of the L6563H: this pin is connected through a resistor divider to the pin VFF (#5) which provides a DC voltage the same as the peak of the MULT pin (#3) signal which is a partition of the rectified mains input voltage. An L6563H internal comparator allows IC operations only if the mains level is correct, within the nominal limits,

therefore at startup, if the input voltage is below 90 Vac (typ.), the circuit operation is inhibited.

The L6699 has a similar protection monitoring the LLC input voltage on the LINE pin (#7). It is used to prevent the resonant converter from working with too low input voltage that may cause incorrect capacitive mode operation and the relevant protection intervention. Therefore, if the bulk voltage (PFC output) is below 380 V (typ.), the resonant stage startup is prevented. The L6699 LINE pin internal comparator has a current hysteresis, allowing to set independently the turn-on and turn-off voltage. Turn-off threshold has been set to 300 V (typ.) in order to avoid capacitive mode operation but allowing the resonant stage to operate even in the case of a whole 20 ms mains cycle sag. Even with the consequent PFC output drop the LLC converter is able to keep the output voltage regulated at the rated load.

1.3 Fast voltage feed-forward

Voltage on the L6563H VFF pin (#5) has the same value as the peak value of the voltage on the MULT pin (#3) and it is generated by the RC network (R15 + R26, C12) connected to VFF, completing an internal peak-holding circuit. This signal is necessary to derive information from the RMS input voltage to compensate the loop gain that is mains voltage dependent.

In general, if the VFF time constant is too small, the voltage generated is affected by a considerable amount of ripple at twice the mains frequency. Because the VFF signal is fed into the multiplier, the excessive ripple causes distortion of the current reference resulting in high THD and poor PF. On the other hand, if the time constant is set too large, there is a considerable delay in setting the right amount of feed-forward, resulting in excessive overshoot or undershoot of the pre-regulator's output voltage in response to large line voltage changes.

To overcome this issue, the L6563H implements the new fast voltage feed-forward function. As soon as the voltage on the VFF pin decreases by a set threshold (40 mV typically), a mains dip is assumed and an internal switch rapidly discharges the VFF capacitor via a 10 k Ω resistor. Thanks to this feature it is possible to set an RC circuit with a long time constant, assuring a low THD, but obtaining a fast response to mains voltage variations by the PFC.

1.4 Resonant power stage

The downstream converter implements the L6699, a double-ended controller specific to the series-resonant half bridge topology, supporting both LLC and LCC configurations. It provides 50% complementary duty cycle: the high-side switch and the low-side switch are driven ON/OFF 180° out-of-phase for exactly the same time. Output voltage regulation is obtained by modulating the operating frequency. The deadtime inserted between the turn-off of one switch and the turn-on of the other is automatically adjusted to best fit the transition times of the half bridge midpoint, allowing the improvement of efficiency thanks to the transformer magnetizing inductance maximization and ensuring zero-voltage switching in all LLC input voltage and output load conditions.

To drive the high-side switch with the bootstrap approach, the L6699 incorporates a high-voltage floating structure able to withstand more than 600 V with an internal synchronous-driven high-voltage DMOS replacing the external fast-recovery bootstrap diode to charge the bootstrap capacitor powering the floating driver of the high-side MOSFET.

The L6699 enables the user to set the operating frequency range of the converter by means of a high-accuracy externally programmable oscillator.

At startup, in addition to the traditional frequency-shift soft-start (the switching frequency starts from a preset maximum value and then decays as far as the steady-state value determined by the control loop), a proprietary circuit controls the half bridge to prevent hard-switching from occurring in the initial cycles because of the imbalance of the VOS applied to the transformer. At light load, the L6699 is forced to enter a controlled burst mode operation that keeps the converter input consumption as low as possible.

IC protection functions include a current sense input for OCP with frequency shift and delayed shutdown with automatic restart. Fast shutdown with automatic restart occurs if this first-level protection cannot control the primary current.

Additionally, the IC prevents the converter from working in, or too close to, capacitive mode, to guarantee soft-switching. A latched disable input (DIS) is used to implement the OVP.

Other functions include a not-latched active-low disable input with current hysteresis, useful for power sequencing or for brownout protection, and an interface with the PFC controller that enables the pre-regulator to be switched off during fault conditions or during burst mode operation.

The transformer uses the integrated magnetic approach, incorporating the resonant series inductance. Therefore no external additional coil is needed for the resonance.

The transformer secondary winding configuration is centre tap and makes use of a couple of power Schottky rectifiers p/n STPS30H60CFP. A small LC filter has been added on the output to reduce the high frequency ripple and noise.

D15, R56, R62, R65, R66, Q5 and Q6 implement an output voltage “fast discharge” circuit discharging quickly the output capacitors when the converter is turned off. It has been implemented to quickly decrease the residual output voltage once the converter is turned off at no load.

1.5 Output voltage feedback loop

The feedback loop is implemented by means of a typical circuit using a TL431 modulating the current in the optocoupler diode.

On the primary side, R34 - connecting pin RFMIN (#4) to the optocoupler's phototransistor - closes the feedback loop and its value sets the maximum switching frequency at about 105 kHz. This value has been chosen to limit the switching losses at light load operation. R31, connecting the same pin to ground, sets the minimum switching frequency. The R-C series R44 and C18 sets both soft-start maximum frequency and duration.

1.6 L6699 overload and short-circuit protection

The current into the primary winding is sensed by the lossless circuit R41, C27, D11, D10, R39, and C25 and it is fed into the ISEN pin (#6). In case of overcurrent, the voltage on the pin surpasses an internal comparator threshold (0.8 V), triggering a protection sequence. The capacitor (C45) connected to the DELAY pin (#2) is charged by an internal 150 μ A current generator and is slowly discharged by the external resistor (R24). If the voltage on the pin reaches 2 V, the soft-start capacitor is completely discharged so that the switching frequency is pushed to its maximum value. As the voltage on the pin exceeds 3.5 V, the IC

stops switching and the internal generator is turned off, so that the voltage on the pin decays because of the external resistor. The IC is soft-restarted as the voltage drops below 0.3 V. In this way, under short-circuit conditions, the converter works intermittently with very low input average power.

Please note that some preliminary demonstration boards use the PCB of the EVL6599A-90WADP reworked for L6699. On these boards the silk screens report the original reference designators for D10 and D11 but have mounted on those positions two resistors in place of the diodes. The name of the boards reported on the PCB silkscreen top side is "90 W adapter with L6563H and L6599A Rev. 1.0".

More recent demonstration boards have updated the reference designators and the silkscreen of D10 and D11 has been updated to R63 and R64 respectively. The name of these more recent boards reported on the PCB top side is "90 W adapter with L6563H and L6699 Rev. 1.0". There is no circuit difference between the two boards.

1.7 Overvoltage and open loop protection

Both circuit stages, PFC and resonant, are equipped with their own overvoltage protection. The L6563H controller monitors the PFC output voltage via the resistor divider connected to a dedicated pin (PFC_OK, #7) protecting the circuit in the case of loop failures or disconnection of the feedback loop divider connected to the INV pin (#1). If a fault condition is detected, the PFC_OK circuitry latches the L6563H operations and, by means of the PWM_LATCH pin (#8), it latches the L6699 too, via its DIS pin (#8). The converter is kept latched by the L6563H HV circuit, which supplies the IC by charging the VCC capacitor periodically. To resume converter operation, a mains restart is necessary.

The LLC open loop protection is guaranteed by the Zener D8 sensing the voltage from the transformer T1 auxiliary winding. In case of open loop the Zener stops the operation by triggering the DIS pin (#8) of the L6699.

1.8 Light load operation

The board implements a burst mode function allowing a significant power saving during light or no-load operation.

The L6699 STBY pin (#5) senses the optocoupler's collector voltage that is related to the feedback control and is proportional to the output load. This signal is compared to an internal reference (1.24 V); if the load decreases and the voltage on the STBY pin becomes lower than the reference, the IC enters an idle state and its quiescent current is reduced. Once the voltage exceeds the reference by 30 mV, the controller restarts switching. Burst mode operation load threshold is programmed by properly choosing the resistor connecting the optocoupler to pin RFmin (R34).

As already mentioned, the deadtime inserted between the two gate driver signals is automatically adjusted to best fit the transition times of the half bridge midpoint, improving the efficiency thanks to the transformer magnetizing inductance maximization. In detail, increasing the transformer magnetizing inductance minimizes the magnetizing current, providing a conduction loss decrease because of the lower total RMS current flowing into the transformer primary side and half bridge MOSFETs. Because of the low current value at MOSFET turn-off, a longer transition time of the half bridge is observed, for this reason the deadtime takes longer in order to ensure the correct zero voltage switching operation by the MOSFETs.

The L6563H implements its own burst mode function. If the COMP voltage falls below 2.5 V, the IC stops switching causing an output voltage decrease, as a consequence the COMP voltage rises again and the IC restarts switching.

In order to achieve a better load transient response, the PFC burst mode operation is partially forced by the resonant converter: once the L6699 stops switching due to load drops, its PFC_STOP pin pulls down the L6563H's PFC_OK pin, disabling PFC switching. Thanks to this solution, the PFC is forced into idle state when the resonant stage is not switching and rapidly wakes up when the downstream converter restarts switching. This solution prevents a significant drop of the bulk voltage in the case of abrupt load rising.

Figure 2. Electrical diagram

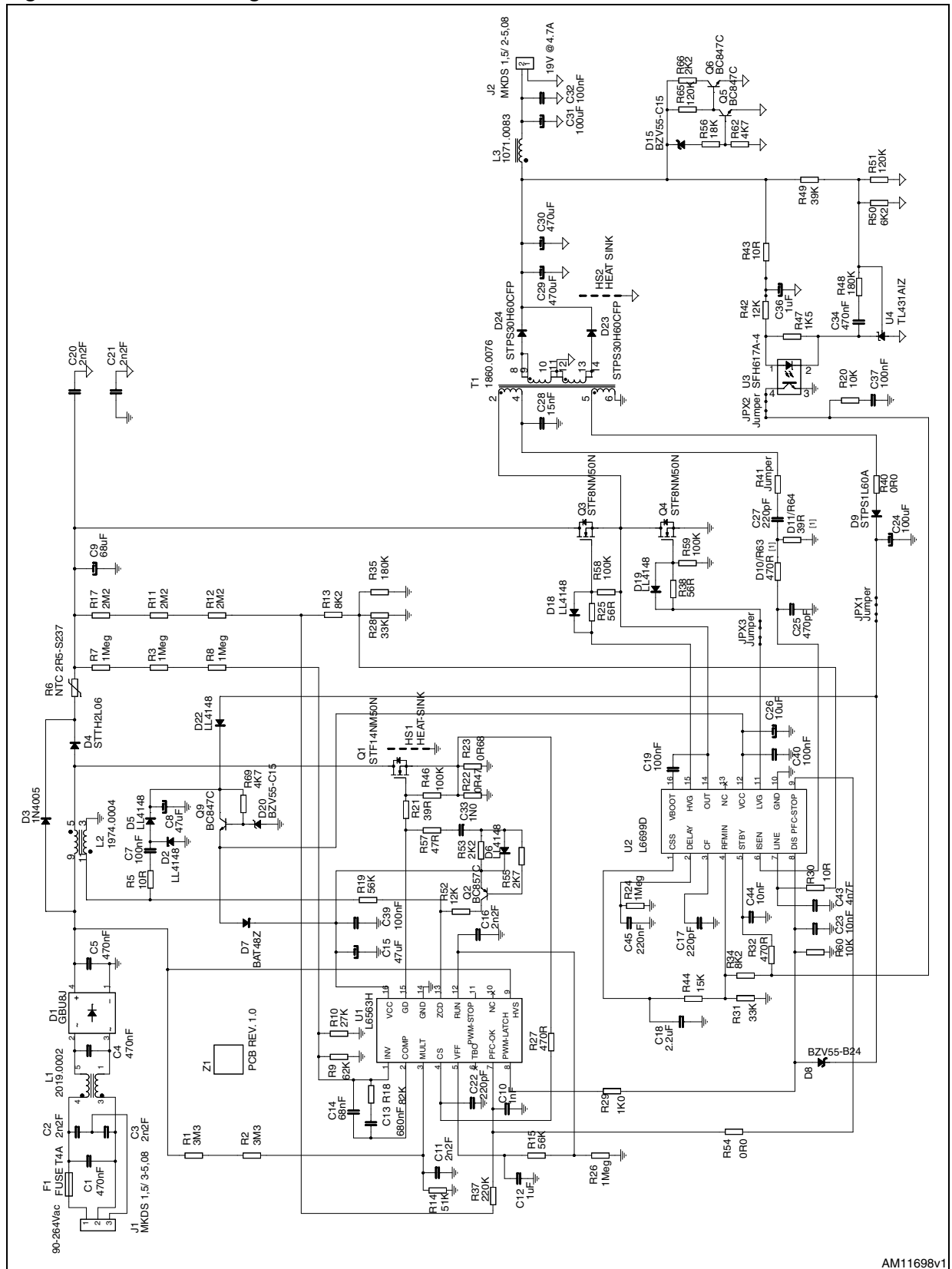

AM11698v1

2 Efficiency measurements

Table 1 shows the no load consumption and the overall efficiency, measured at the nominal mains voltages. At 115 Vac the average efficiency is 89.8%, while at 230 Vac it is 91.5%. Both values are significantly higher than the minimum required by EPA rev2.0 external power supply limits (87%).

Measurements are also reported in Figure 3 for reference.

Even at no load the board performance is superior: maximum no load consumption at nominal mains voltage is less than 200 mW; also this value is significantly lower than the limit imposed by the ENERGY STAR program, which is 500 mW, and it can meet more stringent requirements.

Table 1. Overall efficiency

Test	230 V-50 Hz					115 V-60 Hz				
	Vout [V]	Iout [A]	Pout [W]	Pin [W]	Eff. [%]	Vout [V]	Iout [A]	Pout [W]	Pin [W]	Eff. [%]
100% load eff.	18.75	4.74	88.88	96.70	91.9%	18.75	4.74	88.88	98.90	89.9%
75% load eff.	18.76	3.60	67.54	73.38	92.0%	18.76	3.60	67.54	74.82	90.3%
50% load eff.	18.77	2.40	45.05	49.32	91.34%	18.77	2.40	45.05	49.95	90.2%
25% load eff.	18.79	1.20	22.55	24.86	90.70%	18.78	1.20	22.54	25.39	88.8%
No load	18.98	0.00	0.00	0.186		18.78	0	0	0.162	
Average eff.					91.5%					89.8%

Figure 3. Efficiency vs. output power diagram

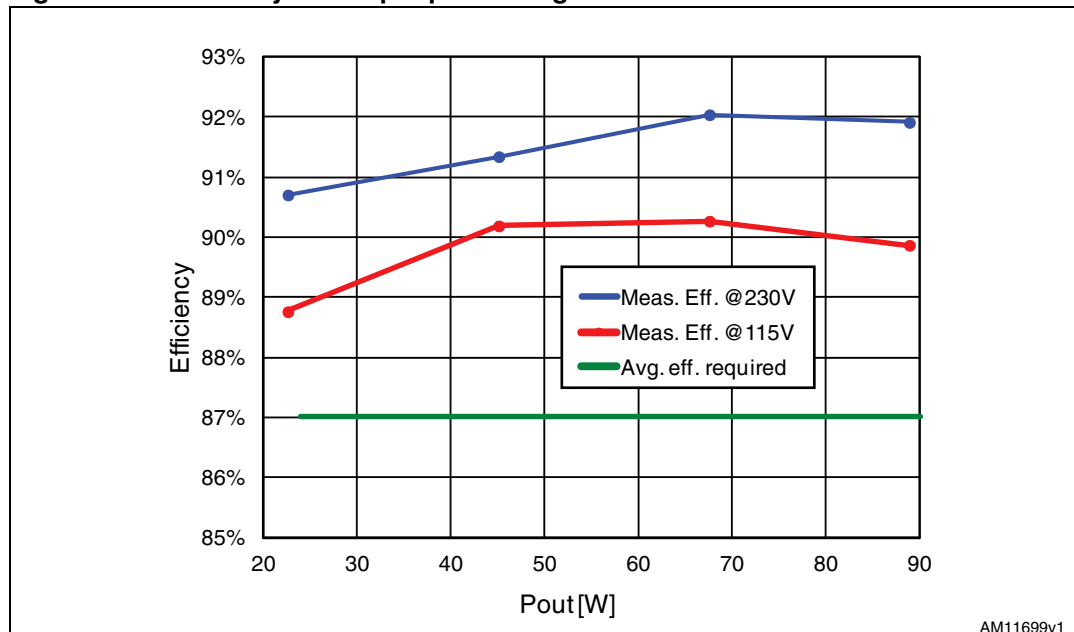

2.1 Light load operation efficiency

Measurement results are reported in [Table 2](#). As seen, efficiency is better than 50% even for very light loads such as 500 mW, as requested by the ErP Lot 6 Tier2 regulation for computers. Such a high light load efficiency makes the board able to meet also the regulation ENERGY STAR version 5.0 program for computers.

Measurement procedure:

1. Because the current flowing through the circuit under measurement is relatively small, the current measurement circuit is connected to the demonstration board side and the voltage measurement circuit is connected to the AC source side. In this way the current absorbed by the voltage circuit is not considered in the measured consumption amount.
2. During any efficiency measurement, remove any oscilloscope probe from the board.
3. For any measurement load, apply a warm-up time of 20 minutes by each different load. Loads have been applied increasing the output power from minimum to maximum.
4. Because of the input current shape during light load condition, the input power measurement may be critical or unreliable using a power meter in the usual way. To overcome the issue, all light measurements have been done by measuring the active energy consumption of the demonstration board under test and then calculating the power as the energy divided by the integration time. The integration time has been set at 36 seconds, as a compromise between a reliable measurement and a reasonable time measurement time. The energy is measured in mWh, the result in mW is then simply calculated by dividing the instrument reading (in mWh) by 100. The instrument used was the Yokogawa WT210 power meter.

Table 2. Light load efficiency

Test	230 V-50 Hz					115 V-60 Hz				
	Vout [V]	Iout [mA]	Pout [W]	Pin [W]	Eff. [%]	Vout [V]	Iout [mA]	Pout [W]	Pin [W]	Eff. [%]
0.125 W	18.79	7.30	0.137	0.342	40.1%	18.79	7.30	0.137	0.335	40.9%
0.25 W	18.79	13.30	0.250	0.47	53.1%	18.79	13.30	0.250	0.470	53.2%
0.5 W	18.79	27.00	0.507	0.760	66.8%	18.79	26.80	0.504	0.776	64.9%
1.0 W	18.79	54.00	1.015	1.335	76.0%	18.79	54.00	1.015	1.378	73.6%
1.5 W	18.79	79.50	1.494	1.876	79.6%	18.79	79.50	1.494	1.954	76.4%
2.0 W	18.79	106.50	2.001	2.446	81.8%	18.79	106.50	2.001	2.556	78.3%
2.5 W	18.79	133.30	2.505	3.030	82.7%	18.79	133.30	2.505	3.148	79.6%
3.0 W	18.79	106.50	3.016	3.598	83.8%	18.79	106.50	3.016	3.734	80.8%
3.5 W	18.79	186.00	3.495	4.138	84.5%	18.79	186.00	3.495	4.283	81.6%
4.0 W	18.79	213.00	4.002	4.708	85.0%	18.79	213.00	4.002	4.860	82.4%
4.5 W	18.79	240.00	4.510	5.269	85.6%	18.79	240.00	4.510	5.430	83.0%
5.0 W	18.79	267.10	5.019	5.832	86.1%	18.79	267.10	5.019	6.007	83.5%

Figure 4. Light load efficiency diagram

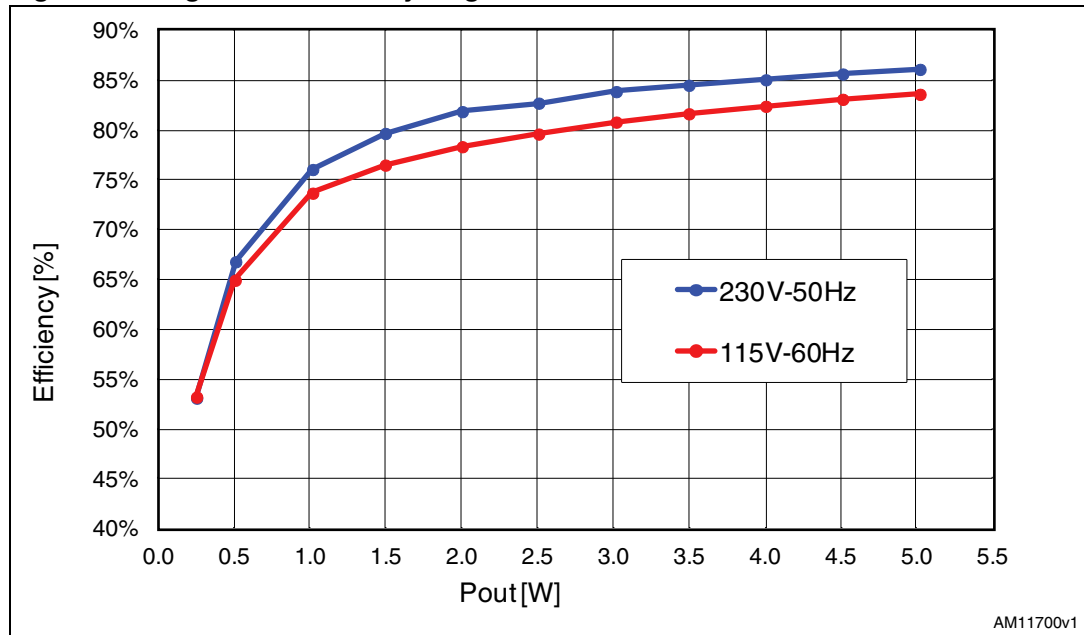

The measurements are reported as a graph in [Figure 4](#). Note that the efficiency is better than 50% in all conditions and it becomes higher than 70% at 1 Watt output power, meeting all worldwide light load consumption regulations such as the ErP Lot 6 Tier2 or the ENERGY STAR program version 5.0 for computers.

3 Harmonic content measurement

The board has been tested against the European standard EN61000-3-2 Class-D and Japanese standard JEITA-MITI Class-D compliance, at both the nominal input voltage mains. As reported in the following figures, the circuit is able to reduce the harmonics well below the limits of both regulations.

On the bottom side of the diagrams the total harmonic distortion and power factor have been measured too. The values in all conditions give a clear idea about the correct functionality of the PFC.

Figure 5. Compliance to EN61000-3-2 at 230 Vac - 50 Hz, full load

Figure 6. Compliance to JEITA-MITI at 100 Vac - 60 Hz, full load

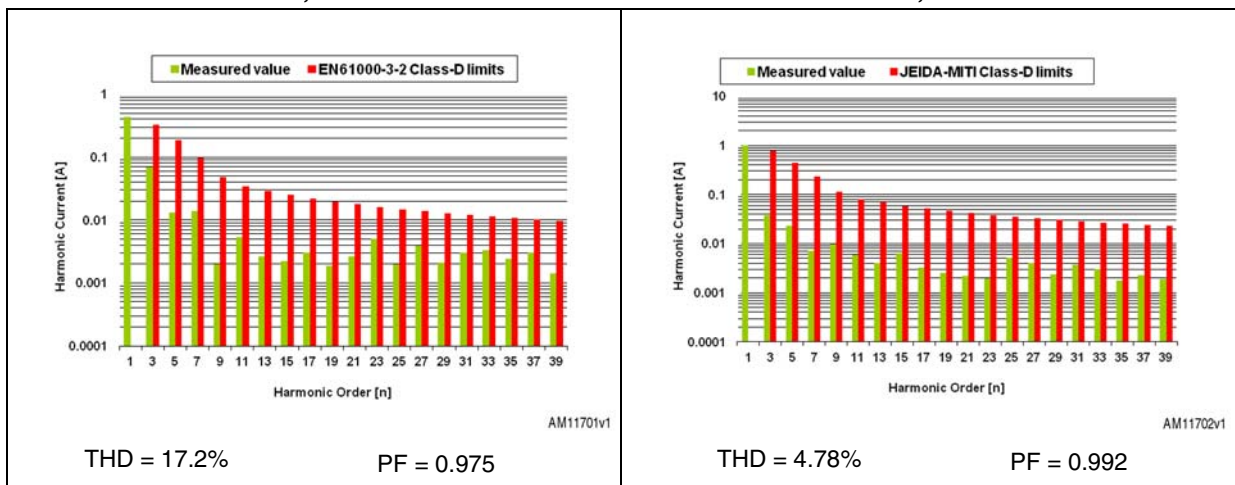

Figure 7 and Figure 8 show the input mains current at both nominal mains input voltages, European and Japanese. At European mains the waveforms show a slightly higher THD value because in order to increase the efficiency, the PFC switching frequency is limited at a value around 130 kHz. However, all harmonics are within the limits specified by both regulations.

Figure 7. Mains voltage and current waveforms at 230 V - 50 Hz - full load

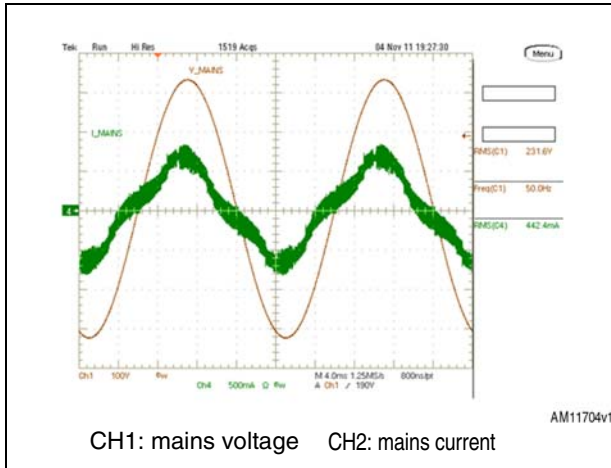
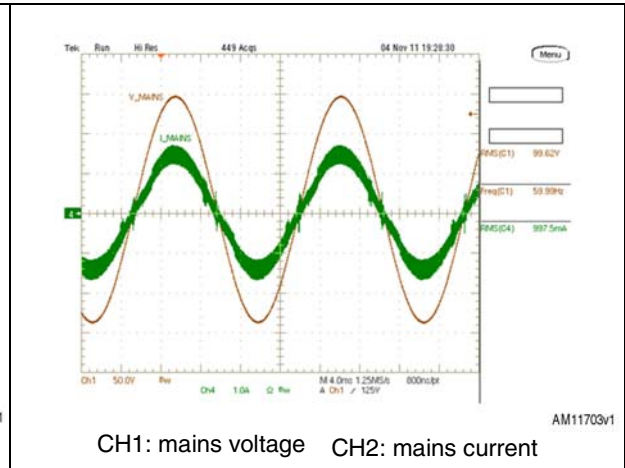

Figure 8. Mains voltage and current waveforms at 100 V - 60 Hz - full load



4 Functional check

The following figures show the waveforms relevant to the resonant stage during steady-state operation. The working frequency during steady-state operation at rated load is about 100 kHz, in order to have a good trade-off between transformer losses and dimensions. The converter operates above the resonance frequency. [Figure 9](#) shows the HB voltage and resonant tank current with both the half bridge driving signals.

In [Figure 10](#) the rectifiers reverse working voltages are captured: the good margin can be noted compared with the BV rectifiers, ensuring reliable, long term operation.

Figure 9. Resonant stage waveforms at 115 V - 60 Hz - full load **Figure 10. Rectifier waveforms at 115 V - 50 Hz - full load**

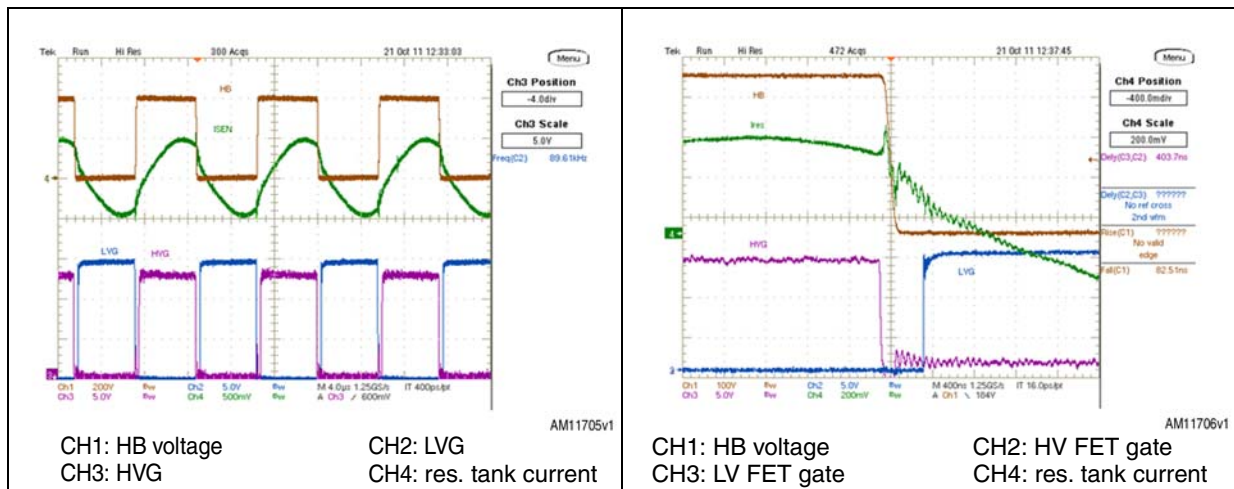

A peculiarity of the L6699 is the self-adaptive deadtime, modulated by the internal logic according to the half bridge node transition time. [Figure 11](#) and [Figure 12](#) show the waveforms during full load operation. It is possible to note the measurement of the edges and the relevant deadtime. It can be seen that both MOSFETs are turned on when resonant current is flowing through their body diodes and drain-source voltage is zero, therefore achieving the MOSFETs zero voltage switching (ZVS) operation at turn-on.

Figure 11. HB transition at full load - rising edge

Figure 12. HB transition at full load - falling edge

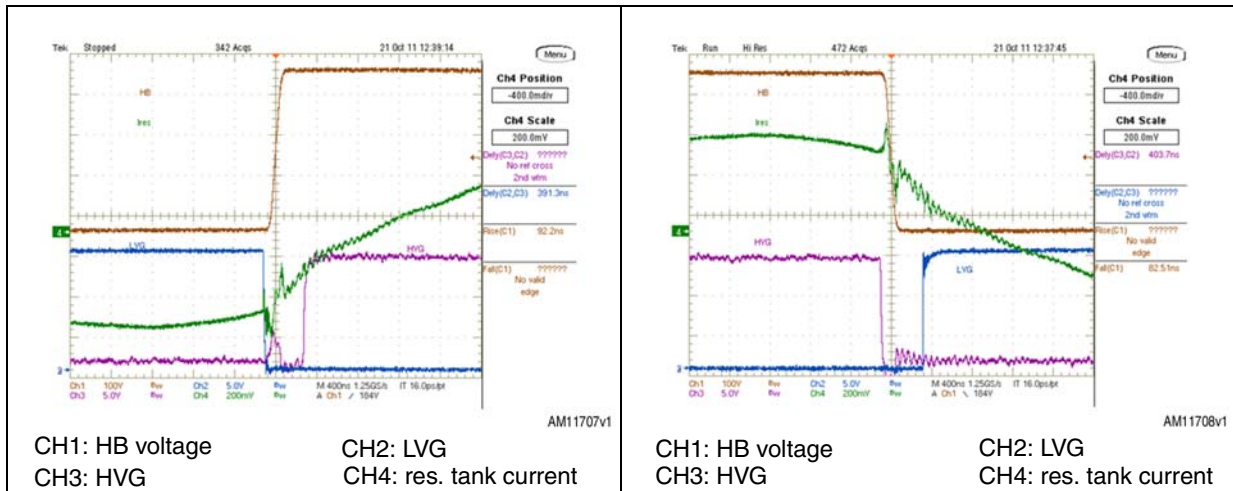

In [Figure 13](#) and [Figure 14](#) the same images are captured during light load operation: note that the half bridge transition is slower because of the lower switched current. In this case the L6699 increases the deadtime maintaining the correct zero voltage switching operation of the circuit. This feature allows the maximization of the transformer magnetizing inductance, therefore obtaining good light load efficiency and also keeping correct operation by the HB.

Figure 13. HB transition at 0.25 A - rising edge Figure 14. HB transition at 0.25 A - falling edge

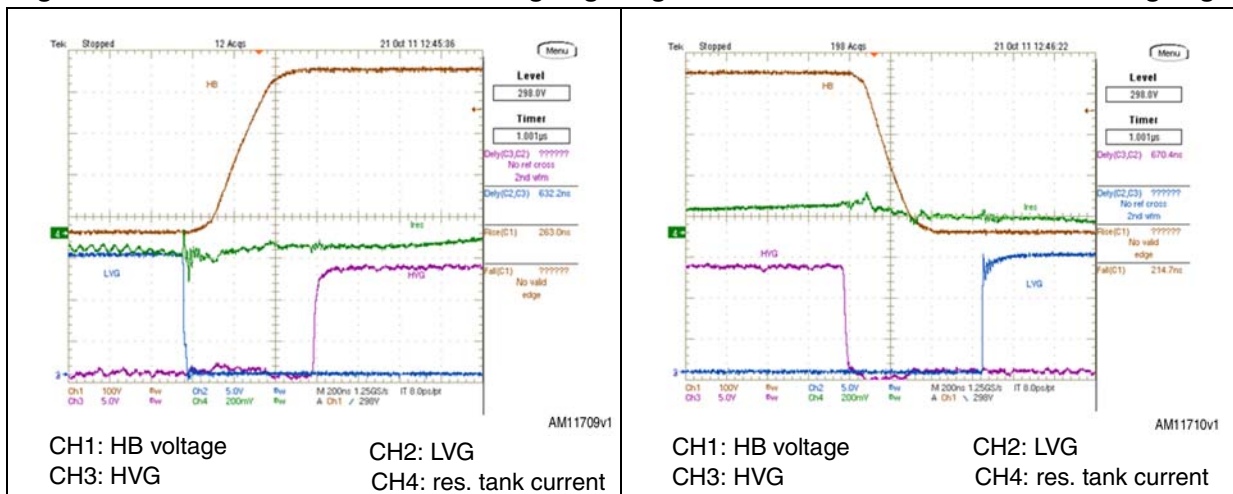

In [Figure 15](#) some signals at the L6699 pins are measured. Note that the signal on pin ISEN (#6) matches the instantaneous current flowing in the transformer primary side. Contrary to the former resonant controllers such as the L6599A and others, requiring an integration of current signal, the L6699 integrates the anti-capacitive mode protection it needs by sensing the instantaneous value of the current, in order to check the phase between the voltage and current. For the same reason, the time constant of the typical RC filter placed between the sensing resistor and the IC pin must be maximum in the range of 200/250 ns. A significant higher value would affect the correct anti-capacitive mode protection because of the phase lag of current signal fed into the L6699.

The LINE pin (#7) has been dimensioned to start up the L6699 once the PFC output voltage has reached the rated value, in order to have correct converter sequencing, with PFC starting first and LLC starting later in order to optimize the design of the LLC converter and prevent capacitive mode operation that may occur because of operation at too low input voltage.

Figure 15. L6699 pin signals-1

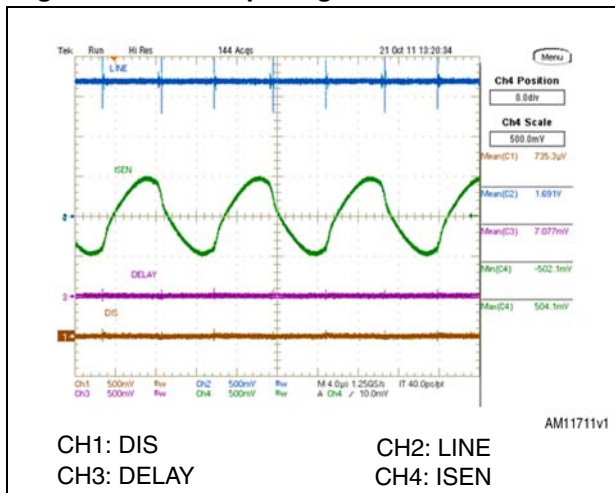
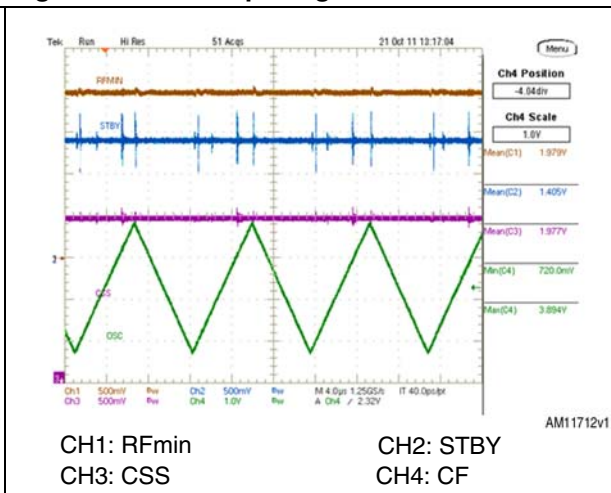

Figure 16. L6699 pin signals-2



The DELAY pin (#2) is zero, as it must be, during normal operation because it works during the overcurrent protection operation. The DIS pin (#8) is used for open loop protection and therefore, even in this case, its voltage is at ground level.

In [Figure 16](#) the pin voltages relevant to the control part of the L6699 are reported: the RFmin pin (#4) is the 2 V (typ.) reference voltage of the oscillator, the switching frequency is proportional to the current flowing out from the pin. The CSS pin (#1) voltage is the same value as pin #4 because it is connected to the latter via a resistor (R44), determining the soft-start frequency. A capacitor (C18) is also connected between the CSS pin and ground to set the soft-start time. At the beginning of L6699 operation the voltage on the CSS pin is at ground level because C18 is discharged, the CSS pin (#1) voltage then increases according to the time constant till the RFmin voltage level is reached. The STBY pin (#5) senses the optocoupler voltage, once the voltage decreases to 1.25 V both gate drivers stop switching and the circuit works in burst mode. The CF pin (#3) is the controller oscillator; its ramp speed is proportional to the current flowing out from the RFmin pin (#4). The CF signal must be clean and undistorted to obtain correct symmetry by the half bridge current, therefore, care must be taken in the layout of the PCB.

4.1 Burst mode operation

In [Figure 17](#) some burst mode pulses are captured during a 250 mW load operation. Note that the burst pulses are very narrow and their period is quite long, therefore the resulting equivalent switching frequency is very low, ensuring high efficiency. The resulting output voltage ripple during burst mode operation is about 58 mV peak-to-peak.

In [Figure 18](#) the detail of the burst is reported: note that the first initial pulse is shorter than the following ones, avoiding the typical high current peak at half bridge operation restart due to the recharging of the resonant capacitor. It is also possible to note that the maximum

operating frequency of the half bridge, set by the resistor R34 in series to the optocoupler, is 103 kHz.

Figure 17. Pout = 250 mW operation

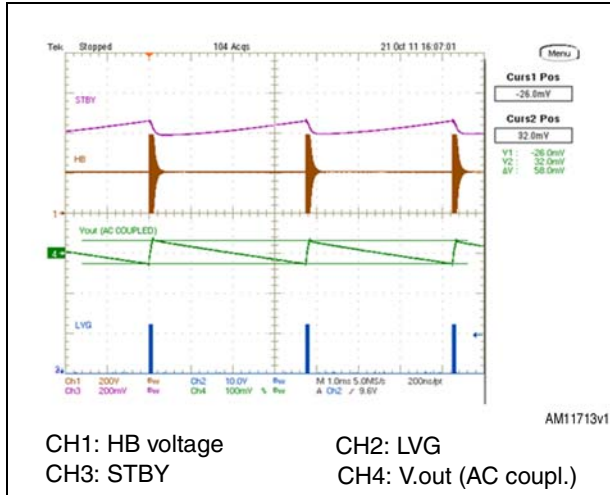
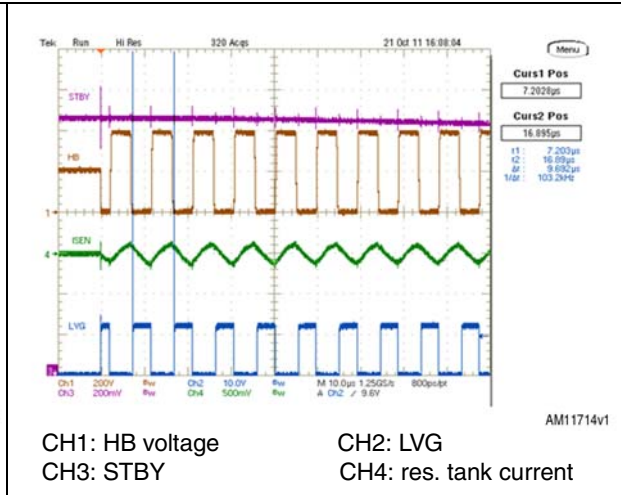

Figure 18. Pout = 250 mW operation - detail



4.2 Startup

The waveforms relevant to the adapter startup at 90 Vac and full load have been captured in [Figure 19](#). The output voltage reaches the nominal value 600 ms after plug-in. The L6563H, HV PFC controller, has an embedded high-voltage startup charging the VCC capacitor by a constant current, ensuring a constant wake-up time. Comparing [Figure 19](#) with [Figure 20](#) relevant to a startup at 265 Vac and no load, the output voltage rises at the nominal level in the same time. In both conditions the output voltage has no overshoot and the rise is monotonic.

Figure 19. Startup at 90 Vac - full load

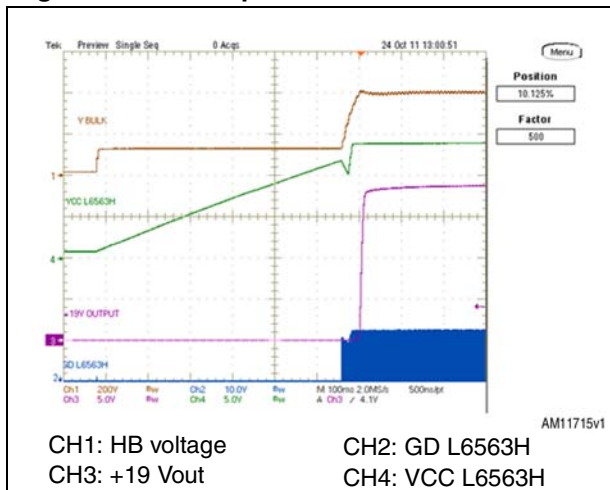
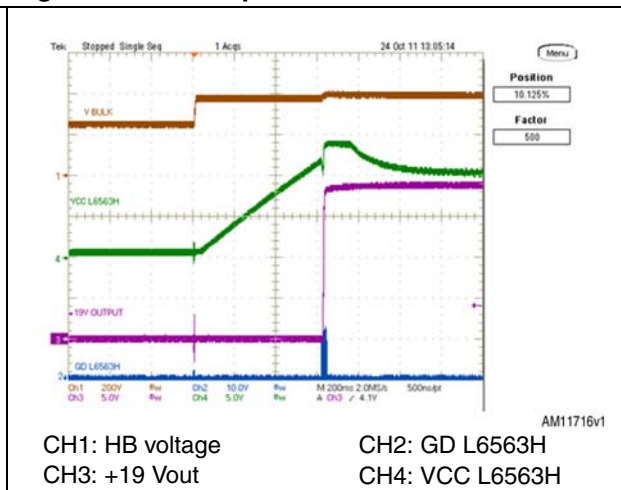

Figure 20. Startup at 265 Vac - no load



In [Figure 21](#) the salient waveforms in the resonant tank during startup of the LLC are reported. In [Figure 22](#) the detail of waveforms at the beginning of operation shows that the resonant circuit is working correctly in zero voltage switching operation from the initial

cycles. In the L6699, a new startup procedure, called “safe-start”, has been implemented to prevent loss of soft-switching during the initial switching cycles, which is typically not guaranteed by the usual soft-start procedure. At startup, the voltage across Cr is often quite different from $V_{in}/2$, as during the normal steady-state operation, so it takes some time for its DC component to reach the steady-state value $V_{in}/2$. During this transient, the transformer is not driven symmetrically and, then, there is a significant V-s imbalance in two consecutive half-cycles. If this imbalance is large, there is a significant difference in the up and down slopes of the tank current and, in a typical controller working with fixed 50% duty cycle, with the duration of the two half-cycles being the same, the current may not reverse in a switching half-cycle. Therefore, one MOSFET can be turned on while the body diode of the other is conducting and this may happen for a few cycles. To prevent this, the L6699 is provided with a proprietary circuit that modifies the normal operation of the oscillator during the initial switching cycles, so that the initial V-s unbalance is nearly eliminated. Its operation is such that current reversal in every switching half-cycle and, then, soft-switching is ensured. In *Figure 22* it is possible to note that at the beginning of operation the duty cycle of the half bridge is initially considerably less than 50%, the tank current has lower peak values and changes sign every half-cycle, while the DC voltage across the resonant capacitor reaches the steady-state. The device goes to normal operation after approximately 50 μ s from the first switching cycle. This transition is nearly seamless and just a small perturbation of the tank current can be observed.

Figure 21. Startup at full load

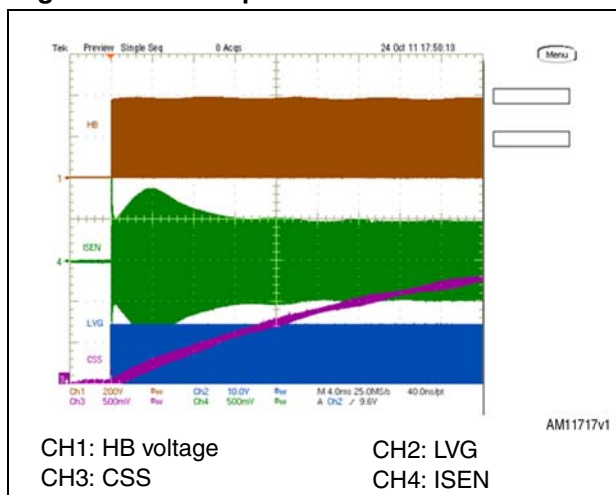
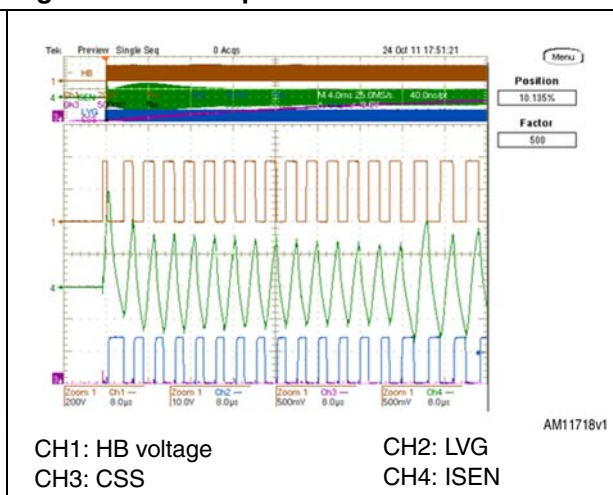

Figure 22. Startup at full load - detail



4.3 Overcurrent and short-circuit protection

The L6699 is equipped with a current sensing input (pin #6, ISEN) and a dedicated overcurrent management system. The current flowing in the resonant tank is detected and the signal is fed into the ISEN pin. It is internally connected to a first comparator, referenced to 0.8 V, and to a second comparator referenced to 1.5 V. If the voltage externally applied to the pin exceeds 0.8 V, the first comparator is tripped causing an internal switch to be turned on and to discharge the soft-start capacitor CSS.

Under output short-circuit, this operation results in a nearly constant peak primary current.

With the L6699, the user can program externally the maximum time that the converter is allowed to run overloaded or under short-circuit conditions. Overloads or short-circuits

lasting less than the set time do not cause any other action, therefore providing the system with immunity to short duration phenomena. If, instead, overload condition keeps going, a protection procedure is activated that shuts down the L6699 and, in the case of continuous overload/short-circuit, results in continuous intermittent operation with a user defined duty cycle. This function is realized with the pin DELAY (#2), by means of a capacitor C45 and the parallel resistor R24 connected to ground. As the voltage on the ISEN pin exceeds 0.8 V, the first OCP comparator, in addition to discharging CSS, turns on an internal 150 μ A current generator that, via the DELAY pin, charges C45. As the voltage on C45 is 3.5 V, the L6699 stops switching and the PFC_STOP pin is pulled low. Also the internal generator is turned off so that C45 is now slowly discharged by R24. The IC restarts when the voltage on C45 is less than 0.3 V. Additionally, if the voltage on the ISEN pin reaches 1.5 V for any reason (e.g. transformer saturation), the second comparator is triggered, the L6699 shuts down and the operation is resumed once the voltage on C45 drops below 0.3 V.

In [Figure 23](#) a dead short-circuit event has been captured. In this case the overcurrent protection is triggered by the second comparator referenced at 1.5 V, it immediately stops switching by the L6699 and discharging of the soft-start capacitor; at the same time the capacitor connected to the DELAY pin (#2) begins charging up to 3.5 V (typ.). Once the voltage on the DELAY pin reaches 3.5 V, the L6699 stops charging the delay capacitor (C45), the L6699 operation is resumed once the DELAY pin (#2) voltage decays to 0.3 V (typ.) by the parallel resistor (R24), via a soft-start cycle. If the short-circuit condition is removed, the converter again starts operation, otherwise, if the short is still there, it results in an intermittent operation (hiccup mode) with a narrow operating duty cycle of the converter, in order to prevent the overheating of power components, as can be noted in [Figure 25](#).

In [Figure 24](#) details of peak current at short-circuit occurring is captured. Note the ZVS correct operation by the half bridge MOSFETs.

Figure 23. Short-circuit at full load

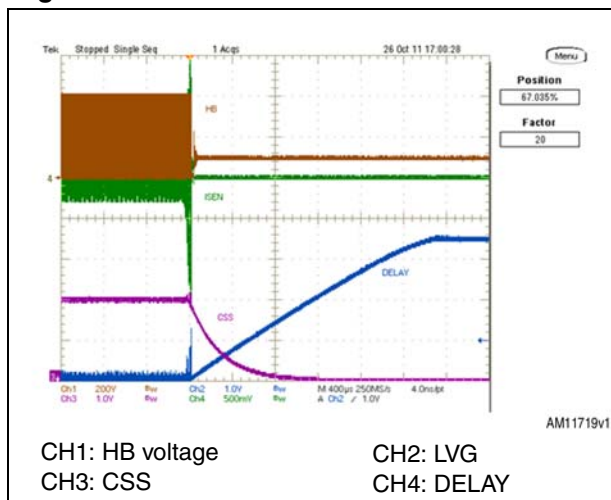

Figure 24. Short-circuit at full load - detail

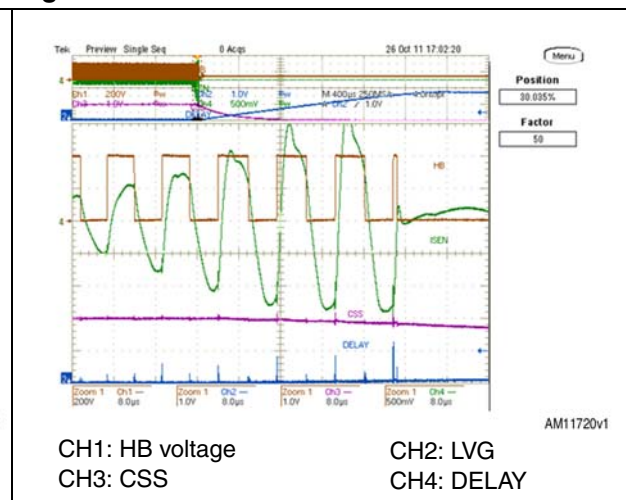
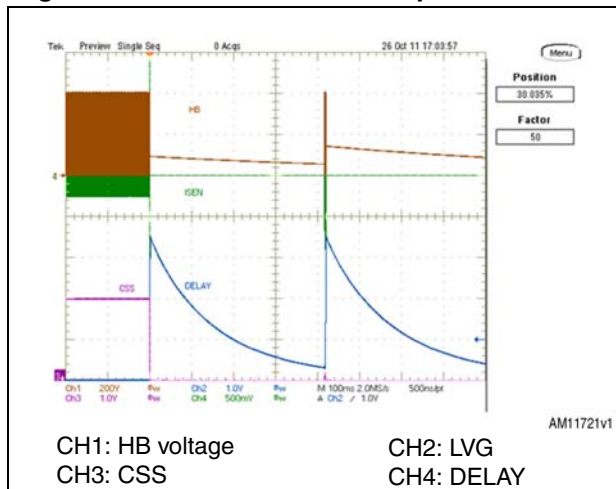

Figure 25. Short-circuit - hiccup mode



4.4 Anti-capacitive mode protection

The EVL6699-90WADP demonstration board has been designed in such a way that the system does not work in capacitive mode during normal operation or failure conditions, as seen in [Figure 24](#), even in dead short condition the LLC operates correctly in the inductive region, the same correct operation occurs during load and input voltage transients.

Normally, the resonant half bridge converter operates with the resonant tank current lagging behind the square-wave voltage applied by the half bridge leg, like a circuit having a reactance of an inductive nature. In this way the applied voltage and the resonant current have the same sign at every transition of the half bridge, which is a necessary condition in order for soft-switching to occur (zero-voltage switching, ZVS at turn-on for both MOSFETs). Therefore, should the phase relationship reverse, i.e. the resonant tank current leading the applied voltage, like in circuits having a capacitive reactance, soft-switching would be lost. This is termed capacitive-mode operation and must be avoided because of its significant drawbacks.

Both MOSFETs feature hard-switching at turn-on, like in conventional PWM-controlled converters (see [Figure 14](#)). The associated capacitive losses may be considerably higher than the total power normally dissipated under “soft-switching” conditions and this may easily lead to their overheating, since heatsinking is not usually sized to handle this abnormal condition.

The body diode of the MOSFET just switched off conducts current during the deadtime and its voltage is abruptly reversed by the other MOSFET turned on ([Figure 14](#)). Therefore, the conducting body diode (which does not generally have great reverse recovery characteristics) keeps its low impedance until it recovers, therefore originating a condition equivalent to a shoot-through of the half bridge leg. This is a potentially destructive condition and causes additional power dissipation due to the current and voltage of the conducting body diode simultaneously high during part of its recovery.

There is an extremely high reverse dv/dt (many tens of V/ns!) experienced by the conducting body diode at the end of its recovery with the other MOSFET turned on. This dv/dt may exceed the rating of the MOSFET and lead to an immediate failure because of the second

breakdown of the parasitic BJT intrinsic in its structure. If a MOSFET is hot, the turn-on threshold of its parasitic BJT is lower, and this dv/dt -induced failure is much more likely.

When either MOSFET is turned on, the other one can be parasitically turned on too, if the current injected through its C_{gd} and flowing through the gate driver's pull-down is large enough to raise the gate voltage close to the turn-on threshold. This would be a lethal shoot-through condition for the half bridge leg.

The recovery of the body diodes generates large and energetic negative voltage spikes because of the unavoidable parasitic inductance of the PCB subject to its di/dt . These are coupled to the OUT pin and may damage the L6699.

There is a large common-mode EMI generation that adversely affects EMC.

Resonant converters work in capacitive mode when their switching frequency falls below a critical value that depends on the loading conditions and the input-to-output voltage ratio. They are especially prone to run into capacitive-mode when the input voltage is lower than the minimum specified and/or the output is overloaded or short-circuited. Designing a converter so that it never works in capacitive-mode, even under abnormal operating conditions, is definitely possible but this may pose unacceptable design constraints in some cases.

To prevent the severe drawbacks of capacitive-mode operation, while enabling a design that needs to ensure inductive-mode operation only in the specified operating range, neglecting abnormal operating conditions, the L6699 provides the capacitive-mode detection function.

The IC monitors the phase relationship between the tank current sensed on the ISEN pin and the voltage applied to the tank circuit by the half bridge, checking that the former lags behind the latter (inductive-mode operation). If the phase-shift approaches zero, which is indicative of impending capacitive-mode operation, the monitoring circuit activates the OCP procedure so that the resulting frequency rise keeps the converter away from that dangerous condition. Also in this case the DELAY pin is activated, so that the OLP function, if used, is eventually tripped after a time TSH causing intermittent operation and reducing thermal stress.

If the phase relationship reverses abruptly (which may happen in the case of dead short at the converter's output), the L6699 is stopped immediately, the soft-start capacitor CSS is totally discharged and a new soft-start cycle is initiated after 50 μ s idle time. During this idle period the PFC_STOP pin is pulled low to stop the PFC stage as well.

5 Thermal map

In order to check the design reliability, a thermal mapping by means of an IR camera was carried out. In *Figure 26* and *27* the thermal measurements of the board, component side, at nominal input voltage are shown. Some pointers visible on the images have been placed across key components or showing high temperature. The ambient temperature during both measurements was 27 °C. All components are working within their operating temperature range with margin.

Figure 26. Thermal map at 115 Vac - 60 Hz - full load.

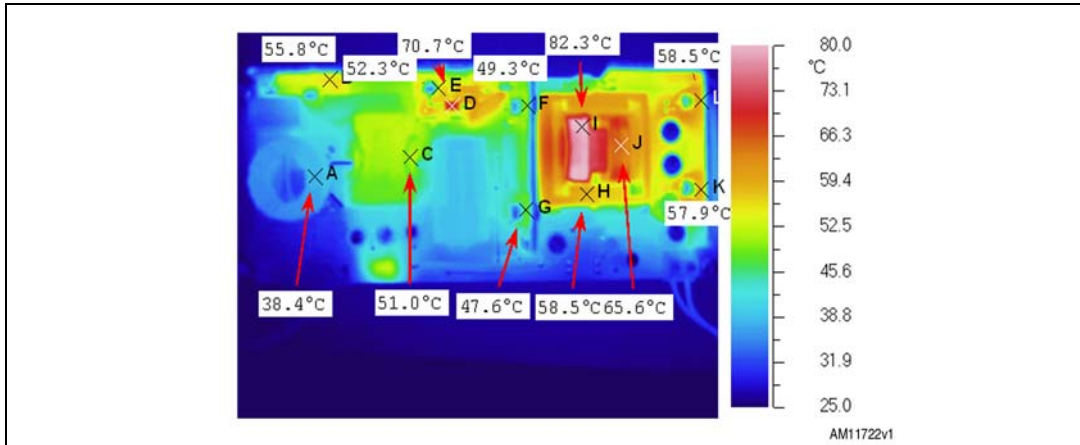

Figure 27. Thermal map at 230 Vac - 50 Hz - full load

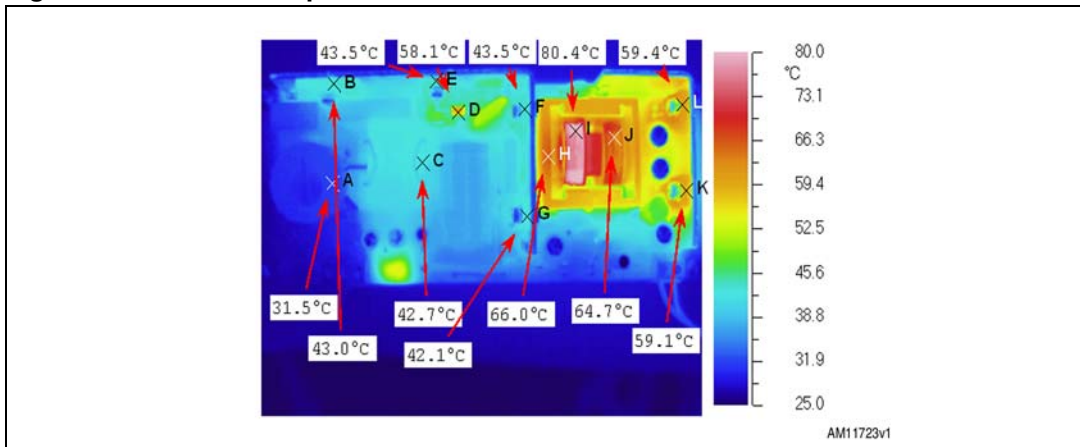

Table 3. Thermal map reference points

Point	Reference	Description
A	L1	EMI filtering inductor
B	D1	Bridge rectifier
C	L2	PFC inductor – hottest point
D	D4	PFC output diode
E	Q1	PFC MOSFET

Table 3. Thermal map reference points (continued)

Point	Reference	Description
F-G	Q3 and Q4	Resonant HB MOSFETs
H-I-J	T1	Resonant power transformer
J-K	D23 and D24	Output rectifiers

6 Conducted emission pre-compliance test

Figure 28 and 29 show the measurements of the conducted noise in average detection, at full load and nominal mains voltages. The limits shown in the diagrams are the EN55022 Class-B ones, which is the most popular rule for domestic equipment and has more severe limits compared to Class-A, dedicated to IT technology equipment. As seen in the diagrams, in all test conditions the measurements are well below the limits.

Figure 28. CE peak measurement at 115 Vac and full load

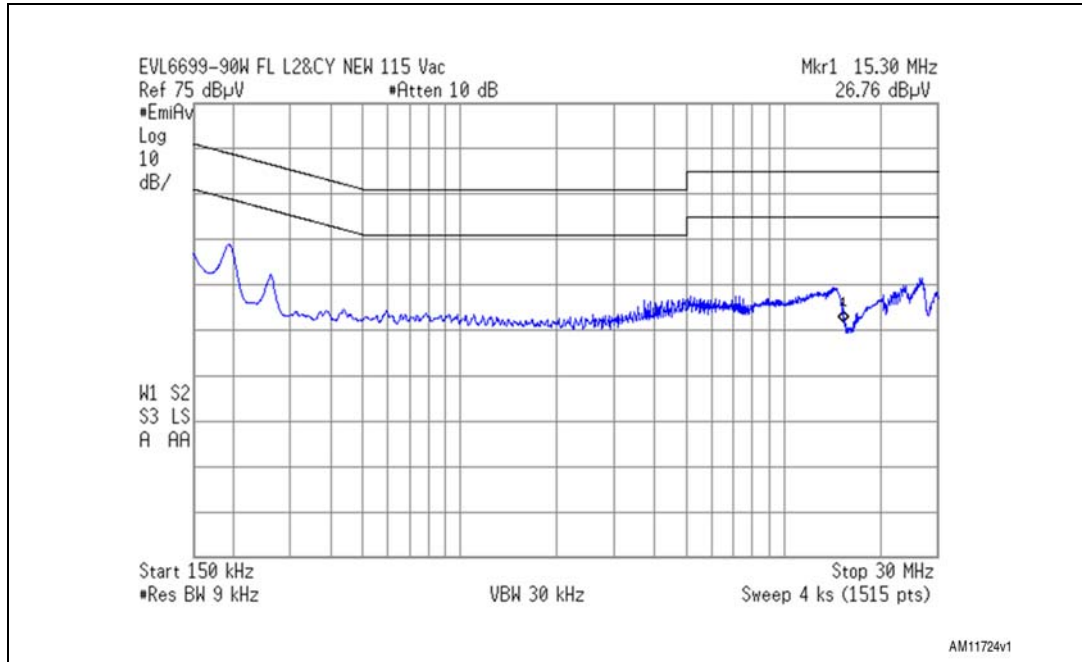
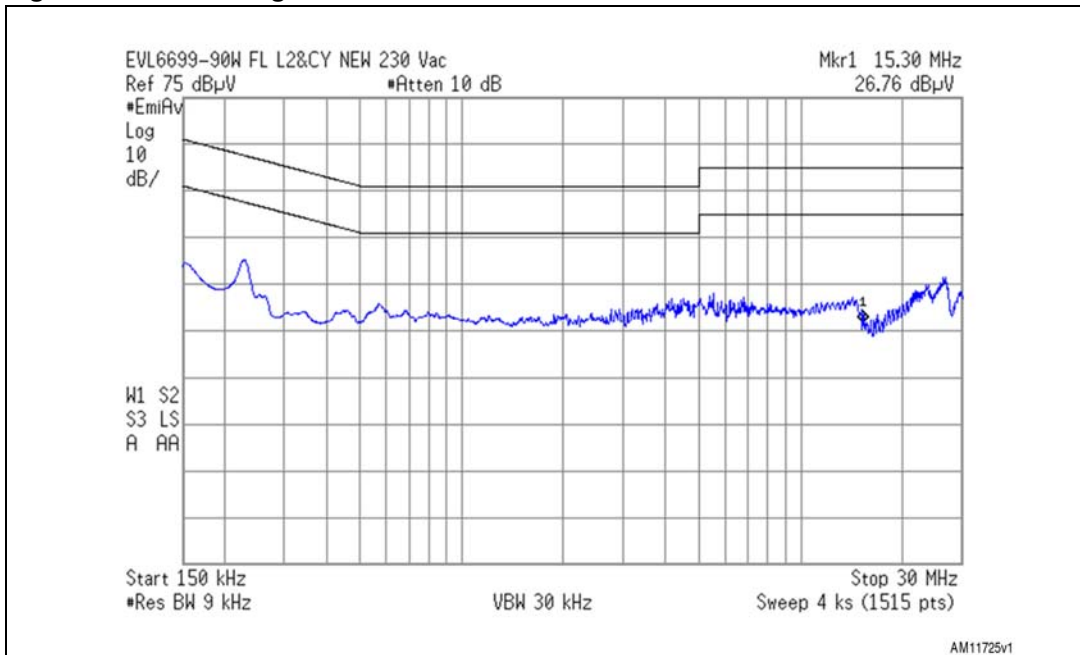

Figure 29. CE average measurement at 230 Vac and full load



7 Bill of material

Table 4. Bill of material

Des.	Part type/ part value	Case style /package	Description	Supplier
C1	470 nF	9.0 x 18.0 p.15 mm	X2 - MKP FILM CAP - B32922C3474K	EPCOS
C2	2n2F	DWG	Y1 CAP. CD12-E2GA222MYGSA	TDK-EPC
C3	2n2F	DWG	Y1 CAP. CD12-E2GA222MYGSA	TDK-EPC
C4	470 nF	9.0 x 18.0 p.15 mm	X2 - MKP FILM CAP - B32922C3474K	EPCOS
C5	470 nF	7.0 x 16.0 p. 22.5 mm	400 V - FILM CAP - B32673Z5474	EPCOS
C6	N.M.	0805	50 V CERCAP - general purpose	
C7	100 nF	PTH	100 V CERCAP - general purpose	AVX
C8	47 µF	Dia. 6.3x11 mm	50 V aluminium ELCAP - YXF series - 105 °C	Rubycon
C9	68 µF	Dia. 18x32 mm	450 V aluminium ELCAP - KXG series - 105 °C	UNITED CHEMICON
C10	1 nF	0805	50 V CERCAP - general purpose	AVX
C11	2n2F	0805	50 V CERCAP - general purpose	AVX
C12	1 µF	0805	25 V CERCAP - general purpose	AVX
C13	680 nF	1206	25 V CERCAP - general purpose	AVX
C14	68 nF	0805	50 V CERCAP - general purpose	AVX
C15	47 µF	Dia. 6.3x11 mm	50 V aluminium ELCAP - YXF series - 105 °C	Rubycon
C16	2n2F	1206	50 V CERCAP - general purpose	AVX
C17	220 pF	0805	50 V - 5% - C0G - CERCAP	AVX
C18	2.2 µF	1206	6.3 V CERCAP - general purpose	AVX
C19	100 nF	1206	50 V CERCAP - general purpose	AVX
C20	2n2F	DWG	Y2 CAP. CS11-E2GA222MYGSA	TDK-EPC
C21	2n2F	DWG	Y2 CAP. CS11-E2GA222MYGSA	TDK-EPC
C22	220 pF	0805	50 V CERCAP - general purpose	AVX
C23	10 nF	0805	50 V CERCAP - general purpose	AVX
C24	100 µF	Dia.10x12.5 mm	50 V aluminium ELCAP - YXF series - 105 °C	Rubycon
C25	470 pF	0805	50 V CERCAP - general purpose	AVX
C26	10 µF	Dia.6.3x11 mm	50 V aluminium ELCAP - YXF series - 105 °C	Rubycon
C27	220 pF	5x3 mm	500 V CERCAP - 5MQ221KAAAA	AVX

Table 4. Bill of material (continued)

Des.	Part type/ part value	Case style /package	Description	Supplier
C28	15 nF	5x18 p.15 mm	1000 V - MKP film cap - B32652A0153K000	EPCOS
C29	470 µF	Dia.10x20 mm	35 V aluminium ELCAP - ZL series - 105 °C	Rubycon
C30	470 µF	Dia.10x20 mm	35 V aluminium ELCAP - ZL series - 105 °C	Rubycon
C31	100 µF	Dia. 8x11 mm	35 V aluminium ELCAP - YXF series - 105 °C	Rubycon
C32	100 nF	0805	50 V CERCAP - general purpose	AVX
C33	1N0	0805	50 V - 5% - C0G - CERCAP	AVX
C34	470 nF	0805	25 V CERCAP - general purpose	AVX
C36	N.M.	Dia. 6.3x11 mm	Not mounted	
C37	100 nF	0805	50 V CERCAP - general purpose	AVX
C39	100 nF	0805	50 V CERCAP - general purpose	AVX
C40	100 nF	1206	50 V CERCAP - general purpose	AVX
C43	4n7F	1206	50 V CERCAP - general purpose	AVX
C44	10 nF	1206	50 V CERCAP - general purpose	AVX
C45	220 nF	0805	25 V CERCAP - general purpose	AVX
C46	N.M.	0805	Not mounted	
D1	GBU8J	STYLE GBU	Single-phase bridge rectifier	Vishay
D2	LL4148	Mini Melf SOD-80	High speed signal diode	Vishay
D3	1N4005	DO-41 DO - 41	General purpose rectifier	Vishay
D4	STTH2L06	DO-41	Ultrafast high-voltage rectifier	STMicroelectronics
D5	LL4148	Mini Melf SOD-80	High speed signal diode	Vishay
D6	LL4148	Mini Melf SOD-80	High speed signal diode	Vishay
D7	BAT48Z	SOD-123	Small signal Schottky diode	STMicroelectronics
D8	BZV55-B24	Mini Melf SOD-80	Zener diode	Vishay
D9	STPS1L60A	SMA	Power Schottky rectifier	STMicroelectronics
D10 (R63)	470R	1206	SMD film res. - 1/4 W - 5% - 250 ppm/°C - [1]	Vishay
D11 (R64)	39R	1206	SMD film res. - 1/4 W - 5% - 250 ppm/°C - [1]	Vishay
D12	N.M.	Mini Melf SOD-80	Not mounted	
D13	N.M.	Mini Melf SOD-80	Not mounted	
D14	N.M.	Mini Melf SOD-80	Not mounted	
D15	BZV55-C15	Mini Melf SOD-80	Zener diode	Vishay

Table 4. Bill of material (continued)

Des.	Part type/ part value	Case style /package	Description	Supplier
D16	N.M.	Mini Melf SOD-80	High speed signal diode	
D17	N.M.	Mini Melf SOD-80	Not mounted	
D18	LL4148	Mini Melf SOD-80	High speed signal diode	Vishay
D19	LL4148	Mini Melf SOD-80	High speed signal diode	Vishay
D20	BZV55-C15	Mini Melf SOD-80	Zener diode	Vishay
D21	N.M.	Mini Melf SOD-80	Zener diode	
D22	LL4148	Mini Melf SOD-80	Fast switching diode	Vishay
D23	STPS30H60CFP	TO-220FP	Power Schottky rectifier	STMicroelectronics
D24	STPS30H60CFP	TO-220FP	Power Schottky rectifier	STMicroelectronics
F1	Fuse T4A	8.5x4 p.5.08 mm	Fuse 4A - time lag - 3921400	LITTLEFUSE
HS1	Heatsink	DWG	Heatsink for D1, Q1, Q3, Q4	
HS2	Heatsink	DWG	Heatsink for D23, D24	
J1	MKDS 1,5/ 3-5,08	DWG	PCB term. block, screw conn., pitch 5 mm - 3 W.	PHOENIX CONTACT
J2	MKDS 1,5/ 2-5,08	DWG	PCB term. block, screw conn., pitch 5 mm - 2 W.	PHOENIX CONTACT
JPX1	Jumper	Wire	Bare copper wire jumper	
JPX2	Jumper	Wire	Bare copper wire jumper	
JPX3	Jumper	Wire	Bare copper wire jumper	
L1	2019.0002		CM inductor 2x18mH 1.8A	MAGNETICA
L2	1974.0004	DWG	PFC inductor - 0.52 mH	MAGNETICA
L3	1071.0083	DWG	Inductor 1 μ H - 5 A	MAGNETICA
Q1	STF12NM50N	TO-220FP	N-channel Power MOSFET	STMicroelectronics
Q2	BC857C	SOT-23	PNP small signal BJT	Vishay
Q3	STF8NM50N	TO-220FP	N-channel Power MOSFET	STMicroelectronics
Q4	STF8NM50N	TO-220FP	N-channel Power MOSFET	STMicroelectronics
Q5	BC847C	SOT-23	NPN small signal BJT	Vishay
Q6	BC847C	SOT-23	NPN small signal BJT	Vishay
Q7	N.M.	SOT-23	PNP small signal BJT - not used	
Q9	BC847C	SOT-23	NPN small signal BJT	Vishay
Q10	N.M.	SOT-23	NPN small signal BJT	
R1	3M3	1206	SMD film res. - 1/4 W - 5% - 250 ppm/ $^{\circ}$ C	Vishay
R2	3M3	1206	SMD film res. - 1/4 W - 5% - 250 ppm/ $^{\circ}$ C	Vishay
R3	1Meg	1206	SMD film res. - 1/4 W - 1% - 100 ppm/ $^{\circ}$ C	Vishay
R4	N.M.	0805	SMD film res. - 1/8 W - 5% - 250 ppm/ $^{\circ}$ C	

Table 4. Bill of material (continued)

Des.	Part type/ part value	Case style /package	Description	Supplier
R5	10R	1206	SMD film res. - 1/4 W - 5% - 250 ppm/°C	Vishay
R6	NTC 2R5-S237	DWG	NTC resistor p/n B57237S0259M000	EPCOS
R7	1Meg	1206	SMD film res. - 1/4 W - 1% - 100 ppm/°C	Vishay
R8	1Meg	1206	SMD film res. - 1/4 W - 1% - 100 ppm/°C	Vishay
R9	62K	0805	SMD film res. - 1/8 W - 1% - 100 ppm/°C	Vishay
R10	27K	0805	SMD film res. - 1/8 W - 1% - 100 ppm/°C	Vishay
R11	2M2	1206	SMD film res. - 1/4 W - 1% - 100 ppm/°C	Vishay
R12	2M2	1206	SMD film res. - 1/4 W - 1% - 100 ppm/°C	Vishay
R13	8K2	1206	SMD film res. - 1/4 W - 1% - 100 ppm/°C	Vishay
R14	51K	0805	SMD film res. - 1/8 W - 5% - 250 ppm/°C	Vishay
R15	56K	1206	SMD film res. - 1/4 W - 1% - 100 ppm/°C	Vishay
R16	N.M.	0805	SMD film res. - 1/8 W - 5% - 250 ppm/°C	
R17	2M2	1206	SMD film res. - 1/4 W - 1% - 100 ppm/°C	Vishay
R18	82K	0805	SMD film res. - 1/8 W - 5% - 250 ppm/°C	Vishay
R19	56K	0805	SMD film res. - 1/8 W - 5% - 250 ppm/°C	Vishay
R20	10K	0805	SMD film res. - 1/8 W - 5% - 250 ppm/°C	Vishay
R21	39R	0805	SMD film res. - 1/8 W - 5% - 250 ppm/°C	Vishay
R22	0R47	PTH	SFR25 axial stand. film res. - 0.4 W - 5% - 250 ppm/°C	Vishay
R23	0R68	PTH	SFR25 axial stand. film res. - 0.4 W - 5% - 250 ppm/°C	Vishay
R24	1Meg	0805	SMD film res. - 1/8 W - 5% - 250 ppm/°C	Vishay
R25	56R	0805	SMD film res. - 1/8 W - 5% - 250 ppm/°C	Vishay
R26	1Meg	0805	SMD film res. - 1/8 W - 1% - 100 ppm/°C	Vishay
R27	470R	1206	SMD film res. - 1/4 W - 5% - 250 ppm/°C	Vishay
R28	33K	0805	SMD film res. - 1/8 W - 1% - 100 ppm/°C	Vishay
R29	1K0	1206	SMD film res. - 1/4 W - 5% - 250 ppm/°C	Vishay
R30	10R	0805	SMD film res. - 1/8 W - 5% - 250 ppm/°C	Vishay
R31	33K	0805	SMD film res. - 1/8 W - 1% - 100 ppm/°C	Vishay
R32	470R	0805	SMD film res. - 1/8 W - 5% - 250 ppm/°C	Vishay
R33	N.M.	0805	Not mounted	
R34	8K2	1206	SMD film res. - 1/4 W - 1% - 100 ppm/°C	Vishay
R35	180K	0805	SMD film res. - 1/8 W - 1% - 100 ppm/°C	Vishay
R36	N.M.	0805	Not mounted	
R37	220K	1206	SMD film res. - 1/4 W - 5% - 250 ppm/°C	Vishay

Table 4. Bill of material (continued)

Des.	Part type/ part value	Case style /package	Description	Supplier
R38	56R	0805	SMD film res. - 1/8 W - 5% - 250 ppm/°C	Vishay
R39	N.M.	0805	SMD film res. - 1/8 W - 5% - 250 ppm/°C	
R40	0R0	1206	SMD film res. - 1/4 W - 5% - 250 ppm/°C	Vishay
R41	Jumper	WIRE	Shorted by wire	
R42	12K	0805	SMD film res. - 1/8 W - 5% - 250 ppm/°C	Vishay
R43	10R	0805	SMD film res. - 1/8 W - 5% - 250 ppm/°C	Vishay
R44	15K	1206	SMD film res. - 1/4 W - 5% - 250 ppm/°C	Vishay
R45	N.M.	0805	Not mounted	
R46	100K	0805	SMD film res. - 1/8 W - 5% - 250 ppm/°C	Vishay
R47	1K5	0805	SMD film res. - 1/8 W - 5% - 250 ppm/°C	Vishay
R48	180K	0805	SMD film res. - 1/8 W - 5% - 250 ppm/°C	Vishay
R49	39K	0805	SMD film res. - 1/8 W - 1% - 100 ppm/°C	Vishay
R50	6K2	0805	SMD film res. - 1/8 W - 1% - 100 ppm/°C	Vishay
R51	120K	0805	SMD film res. - 1/8 W - 1% - 100 ppm/°C	Vishay
R52	12K	0805	SMD film res. - 1/8 W - 5% - 250 ppm/°C	Vishay
R53	2K2	0805	SMD film res. - 1/8 W - 5% - 250 ppm/°C	Vishay
R54	0R0	0805	SMD film res. - 1/8 W - 5% - 250 ppm/°C	Vishay
R55	2K7	0805	SMD film res. - 1/8 W - 5% - 250 ppm/°C	Vishay
R56	18K	0805	SMD film res. - 1/8 W - 5% - 250 ppm/°C	Vishay
R57	47R	0805	SMD film res. - 1/8 W - 5% - 250 ppm/°C	Vishay
R58	100K	0805	SMD film res. - 1/8 W - 5% - 250 ppm/°C	Vishay
R59	100K	0805	SMD film res. - 1/8 W - 5% - 250 ppm/°C	Vishay
R60	10K	0805	SMD film res. - 1/8 W - 5% - 250 ppm/°C	Vishay
R61	N.M.	0805	SMD film res. - 1/8 W - 5% - 250 ppm/°C	
R62	4K7	0805	SMD film res. - 1/8 W - 5% - 250 ppm/°C	Vishay
R65	120K	0805	SMD film res. - 1/8 W - 5% - 250 ppm/°C	Vishay
R66	2K2	1206	SMD film res. - 1/4 W - 5% - 250 ppm/°C	Vishay
R67	N.M.	0805	Not mounted	
R68	N.M.	1206	Not mounted	
R69	4K7	0805	SMD film res. - 1/8 W - 5% - 250 ppm/°C	Vishay
T1	1860.0076	DWG - ETD34	Resonant power transformer	MAGNETICA
U1	L6563H	SO-16	High-voltage startup TM PFC controller	STMicroelectronics
U2	L6699D	SO-16	Improved HV resonant controller	STMicroelectronics
U3	SFH617A-4	DIP-4 - 10.16 mm	Optocoupler	INFINEON

Table 4. Bill of material (continued)

Des.	Part type/ part value	Case style /package	Description	Supplier
U4	TL431AIZ	TO-92	Programmable shunt voltage reference	STMicroelectronics
Z1	PCB REV. 1.0			

Note: Some preliminary demonstration boards use the PCB of the EVL6599A-90WADP reworked for the L6699. On these boards the silkscreen reports the original reference designators of these components as D10 and D11, like in the circuit diagram of the EVL6599A-90WADP. The name of the boards reported on the PCB silkscreen top side is "90 W adapter with the L6563H and L6599A Rev. 1.0". More recent demonstration boards have updated the reference designators and the silkscreen of D10 and D11 has been updated to R63 and R64 respectively. The name of these more recent boards reported on the PCB top side is "90 W adapter with the L6563H and L6699 Rev. 1.0". There isn't any circuit difference between the two boards.

8 PFC coil specifications

8.1 General description and characteristics

- Application type: consumer, home appliance
- Transformer type: open
- Coil former: vertical type, 6+6 pins
- Max. temperature rise: 45 °C
- Max. operating ambient temperature: 60 °C
- Mains insulation: n.a.
- Unit finishing: varnished.

8.2 Electrical characteristics

- Converter topology: boost, transition mode
- Core type: PQ26/20-PC44 or equivalent
- Min. operating frequency: 40 kHz
- Typical operating frequency: 120 kHz
- Primary inductance: 520 $\mu\text{H} \pm 15\%$ at 1 kHz - 0.25 V^(a).

8.3 Electrical diagram and winding characteristics

Figure 30. PFC coil electrical diagram

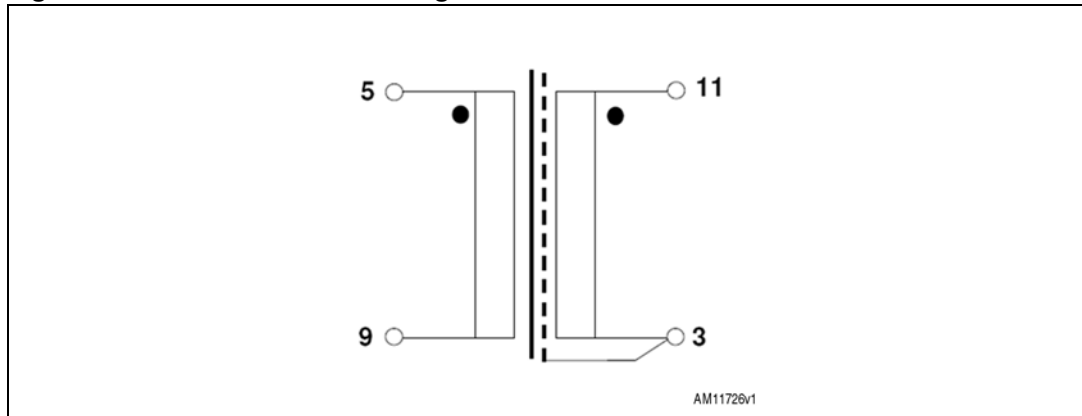

Table 5. PFC coil winding data

Pins	Windings	DC resistance	Number of turns	Wire type
11-3	AUX	125 m Ω	5.5	ϕ 0.28 mm – G2
5-9	Primary	267 m Ω	57.5	30X ϕ 0.1 mm- G1

a. Measured between pins #5 and #9.

8.4 Mechanical aspect and pin numbering

- Maximum height from PCB: 22 mm
- Coil former type: vertical, 6+6 pins (pins #1, 2, 4, 6, 7, 10, 12 are removed)
- Pin distance: 3.81 mm
- Row distance: 25 mm
- External copper shield: not insulated, wound around the ferrite core and including the coil former. Height is 8 mm. Connected to pin #3 by a soldered solid wire.

Figure 31. PFC coil mechanical aspect

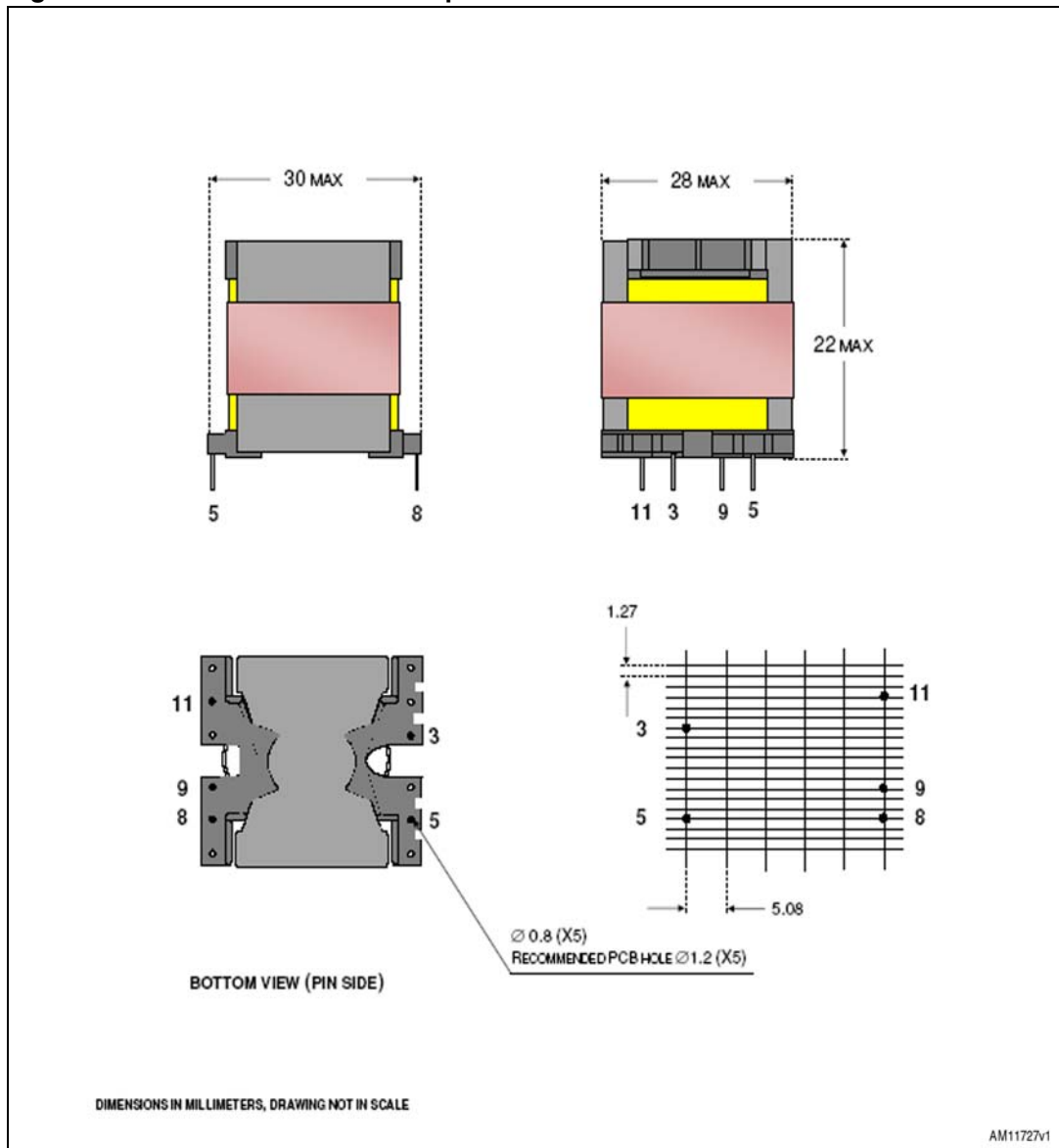

Manufacturer

- MAGNETICA - Italy
- Inductor p/n: 1974.0004.

9 Transformer specifications

9.1 General description and characteristics

- Application type: consumer, home appliance
- Transformer type: open
- Coil former: horizontal type, 7+7 pins, two slots
- Max. temperature rise: 45 °C
- Max. operating ambient temperature: 60 °C
- Mains insulation: acc. to EN60065.

9.2 Electrical characteristics

- Converter topology: half bridge, resonant
- Core type: ETD34-PC44 or equivalent
- Min. operating frequency: 60 kHz
- Typical operating frequency: 90 kHz
- Primary inductance: 2.00 mH \pm 10% at 1 kHz - 0.25 V^(b)
- Leakage inductance: 300 μ H at 100 kHz - 0.25 V^(c).

9.3 Electrical diagram and winding characteristics

Figure 32. Transformer electrical diagram

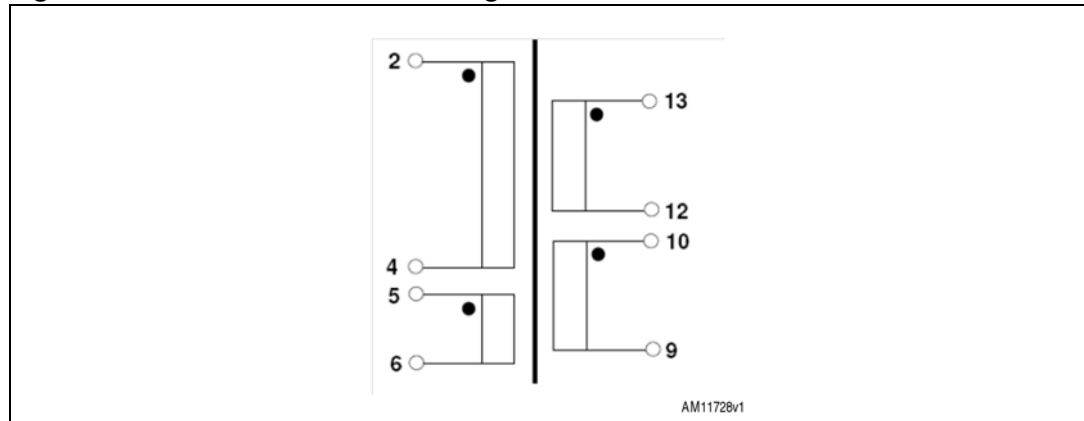

b. Measured between pins 2-4.

c. Measured between pins 2-4 with only one secondary winding shorted.

Table 6. Transformer winding data

Pins	Winding	DC resistance	Number of turns	Wire type
2-4	Primary	422 mΩ	61	20x φ 0.1 mm – G1
13-12	SEC - A ⁽¹⁾	8 mΩ	6	60x φ 0.1 mm – G1
10-9	SEC – B	8 mΩ	6	60x φ 0.1 mm – G1
5-6	AUX ⁽²⁾	111 mΩ	4	φ 0.28 mm – G2

1. Secondary windings A and B are in parallel.
2. Aux winding is wound on top of primary winding.

9.4 Mechanical aspect and pin numbering

- Maximum height from PCB: 30 mm
- Coil former type: horizontal, 7+7 pins (pins #1 and 7 are removed)
- Pin distance: 5.08 mm
- Row distance: 25.4 mm

Figure 33. Transformer overall drawing

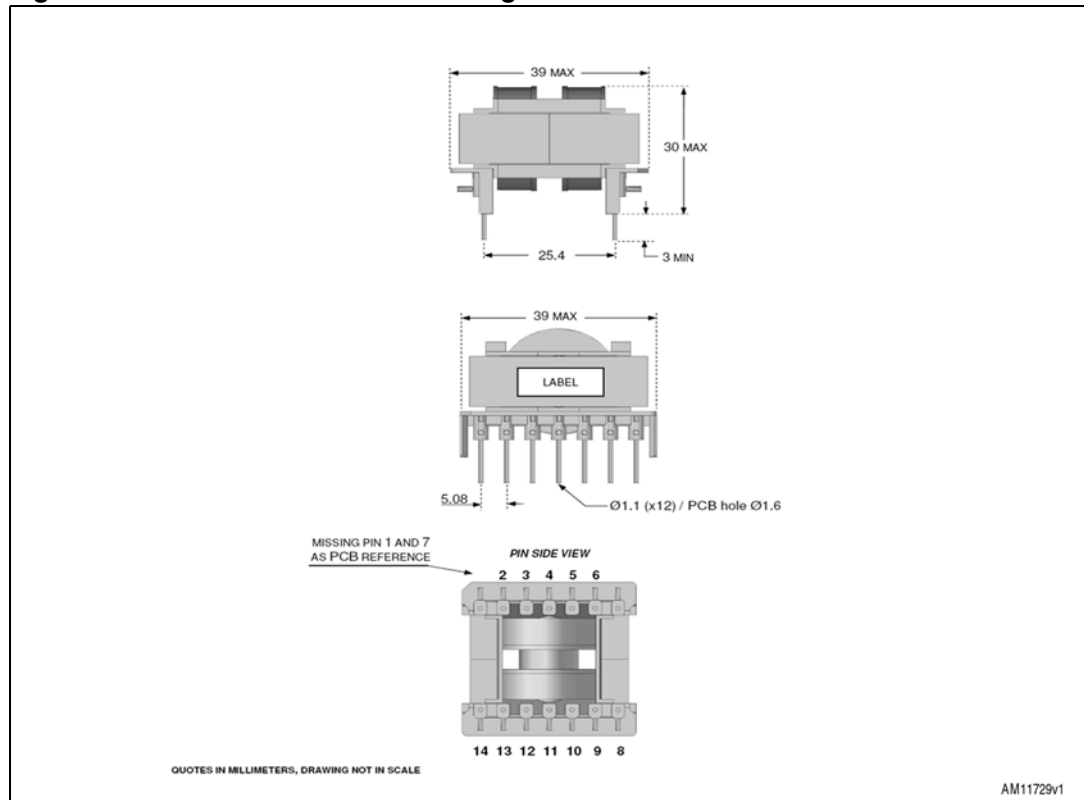

Manufacturer

- MAGNETICA - Italy
- Transformer p/n: 1860.0076.

10 Revision history

Table 7. Document revision history

Date	Revision	Changes
23-Jul-2012	1	Initial release.

Please Read Carefully:

Information in this document is provided solely in connection with ST products. STMicroelectronics NV and its subsidiaries ("ST") reserve the right to make changes, corrections, modifications or improvements, to this document, and the products and services described herein at any time, without notice.

All ST products are sold pursuant to ST's terms and conditions of sale.

Purchasers are solely responsible for the choice, selection and use of the ST products and services described herein, and ST assumes no liability whatsoever relating to the choice, selection or use of the ST products and services described herein.

No license, express or implied, by estoppel or otherwise, to any intellectual property rights is granted under this document. If any part of this document refers to any third party products or services it shall not be deemed a license grant by ST for the use of such third party products or services, or any intellectual property contained therein or considered as a warranty covering the use in any manner whatsoever of such third party products or services or any intellectual property contained therein.

UNLESS OTHERWISE SET FORTH IN ST'S TERMS AND CONDITIONS OF SALE ST DISCLAIMS ANY EXPRESS OR IMPLIED WARRANTY WITH RESPECT TO THE USE AND/OR SALE OF ST PRODUCTS INCLUDING WITHOUT LIMITATION IMPLIED WARRANTIES OF MERCHANTABILITY, FITNESS FOR A PARTICULAR PURPOSE (AND THEIR EQUIVALENTS UNDER THE LAWS OF ANY JURISDICTION), OR INFRINGEMENT OF ANY PATENT, COPYRIGHT OR OTHER INTELLECTUAL PROPERTY RIGHT.

UNLESS EXPRESSLY APPROVED IN WRITING BY TWO AUTHORIZED ST REPRESENTATIVES, ST PRODUCTS ARE NOT RECOMMENDED, AUTHORIZED OR WARRANTED FOR USE IN MILITARY, AIR CRAFT, SPACE, LIFE SAVING, OR LIFE SUSTAINING APPLICATIONS, NOR IN PRODUCTS OR SYSTEMS WHERE FAILURE OR MALFUNCTION MAY RESULT IN PERSONAL INJURY, DEATH, OR SEVERE PROPERTY OR ENVIRONMENTAL DAMAGE. ST PRODUCTS WHICH ARE NOT SPECIFIED AS "AUTOMOTIVE GRADE" MAY ONLY BE USED IN AUTOMOTIVE APPLICATIONS AT USER'S OWN RISK.

Resale of ST products with provisions different from the statements and/or technical features set forth in this document shall immediately void any warranty granted by ST for the ST product or service described herein and shall not create or extend in any manner whatsoever, any liability of ST.

ST and the ST logo are trademarks or registered trademarks of ST in various countries.

Information in this document supersedes and replaces all information previously supplied.

The ST logo is a registered trademark of STMicroelectronics. All other names are the property of their respective owners.

© 2012 STMicroelectronics - All rights reserved

STMicroelectronics group of companies

Australia - Belgium - Brazil - Canada - China - Czech Republic - Finland - France - Germany - Hong Kong - India - Israel - Italy - Japan - Malaysia - Malta - Morocco - Philippines - Singapore - Spain - Sweden - Switzerland - United Kingdom - United States of America

www.st.com